

WILDWASSERBAHN »PIRATENINSEL«

»PIRATE ISLAND« WILDWATER CANOEING COURSE
PARCOURSE DE TORRENT »ILE AUX PIRATES«
WILDWATERBAAN »PIRATENEILAND«



Art. Nr. 140430

- D** Vor Beginn des Bastelns sollten Sie sich mit den Spritzlingen und der Anleitung vertraut machen. Sollte es einmal vorkommen, dass ein Teil im Bausatz fehlt, kreuzen Sie bitte das fehlende Teil in der Anleitung an und schicken Sie diese bitte an Fa. Gebr. FALLER GmbH, Abt. Kundendienst, kundendienst@faller.de, Kreuzstraße 9, 78148 Gütenbach. Sie erhalten dann umgehend Ersatz. In diesem Bausatz sind einige Kunststoffteile übrig.
- GB** Before beginning with the assembly please familiarize yourself with the parts and read the instructions carefully. In case of missing parts please indicate these on the instructions leaflet with a circle and return the leaflet to Gebr. FALLER GmbH, kundendienst@faller.de, Kreuzstraße 9, D-78148 Gütenbach, Germany. You will receive the replacement by return. Some of the parts in this box are not needed to construct the model.
- F** Avant de commencer le montage de votre maquette bien lire la notice et repérer les grappes. Si une pièce manque dans une boîte, cochez la pièce correspondante sur la notice et renvoyez-la-nous à Gebr. FALLER GmbH, kundendienst@faller.de, Kreuzstraße 9, D-78148 Gütenbach (R.F.A.). Nous vous ferons parvenir la pièce par retour. Dans cette boîte se trouvent quelques pièces qui ne seront pas utilisées pour le montage.
- NL** Vóór het bouwen zou men de gietstukken en de handleiding moeten bestuderen. Indien onverhoopt een onderdeel aan het bouwpakket ontbreekt, gelieve men het ontbrekende deel in de handleiding aan te kruisen en deze te zenden aan Gebr. FALLER GmbH, kundendienst@faller.de, Kreuzstraße 9, D-78148 Gütenbach. U ontvangt dan omgaand en gratis het ontbrekende onderdeel. Van dit bouwpakket worden enkele kunststof delen niet gebruikt.



Art. Nr. 170492
FALLER-EXPERT

Flüssigkleber in Plastikflasche mit Spezialkanüle für feinste Klebstoffdosierung.

Liquid cement in plastic bottle with canule for very fine dosage.

Colle liquide en bouteille plastique avec bec verseur pour un dosage précis.

Vloeibare lijm in plastic-flacon met doseerbuisje om nauwkeurig te lijmen.



Art. Nr. 170688
SPEZIAL-SEITENSCHNEIDER

zum gratfreien Abtrennen von feinsten Spritzteilen. Nur für Polystyrol geeignet.

Special side cutter for cutting off ultra-fine moulded parts without burrs. Only suitable for polystyrene.

Pince coupante spéciale pour couper sans bavure les pièces miniatures moulées par injection. Convient uniquement au polystyrène.

Speciale zijknijptang voor het braamloos afknippen van de fijnste gietstukdelen. Alleen geschikt voor polystyrol.

- D** Beim Zusammenbau des Modells ist es wichtig, die Hinweise »nicht kleben« genau zu beachten. Werden diese Hinweise nicht beachtet, ist das Modell nicht funktionsfähig. Alle beweglichen Teile müssen leicht gängig sein. Alle Lagerstellen mit einem Tropfen FALLER-Öl Art.Nr. 180489 ganz leicht einölen. Nur säure und harzfreies Öl verwenden.
- GB** When the model is being assembled, it is essential that the »do not glue« instructions should be observed. Failure to do so will render the model inoperational. Make sure that all moving parts work smoothly. Sparingly oil all bearing points by applying a drop of FALLER oil, art. no. 180489. Use acid and resin-free oil only.
- F** Au cours du montage du modèle, il est important de respecter très exactement les indications: »Ne pas coller«. Si ces indications ne sont pas respectées, le modèle ne pourra fonctionner correctement. Toutes les parties mobiles doivent être en bon état de marche. Enduire légèrement tous les points d'appui d'une goutte d'huile FALLER, (Article 180489). Ne pas utiliser d'huile d'acide ou de résine.
- NL** Bij de bouw van het model is het belangrijk te letten op de »aanwijzingen »niet lijmen«. Als deze aanwijzingen niet worden opgevolgd zal het model niet functioneren. Alle bewegbare delen moeten gemakkelijk kunnen draaien. Alle draaipunten moeten licht worden geolied met een druppel FALLER-olie nr. 180489. Alleen zuur- en harsvrije olie gebruiken.

Für die Montage benötigen Sie Plastik-Klebstoff, Sekundenkleber und einen Öler. Wir empfehlen:
FALLER-Klebstoff EXPERT (170492)
FALLER-Sekundenkleber EXPERT-RAPID (170500)
FALLER-Spezial-Öler (170489)
FALLER-Spezial-Seitenschneider (170688)
FALLER-Bastelmesser (170687)

For mounting you need plastic cement, split-second modelling cement and an oiler. Our recommendation:
FALLER cement EXPERT (170492)
FALLER split-second modelling cement EXPERT-RAPID (170500)
FALLER special oiler (170489)
FALLER special side cutter (170688)
FALLER modeller's knife (170687)

Pour le montage, utiliser de la colle plastique, de la colle rapide et un huileur spéciale. Nous vous recommandons les produits suivants:
Colle FALLER EXPERT (170492)
Colle rapide FALLER-RAPID (170500)
Huileur spéciale FALLER (170489)
Pince coupante diagonale spéciale FALLER (170688)
Couteau de bricolage FALLER (170687)

Voor de montage heeft u plasticlijm, secondenlijm en olie nodig. Wij adviseren:
FALLER-plasticlijm EXPERT (170492)
FALLER-secondenlijm EXPERT-RAPID (170500)
FALLER-speciale olie (170489)
FALLER-speciale zijknijptang (170688)
FALLER-knutselmes (170687)

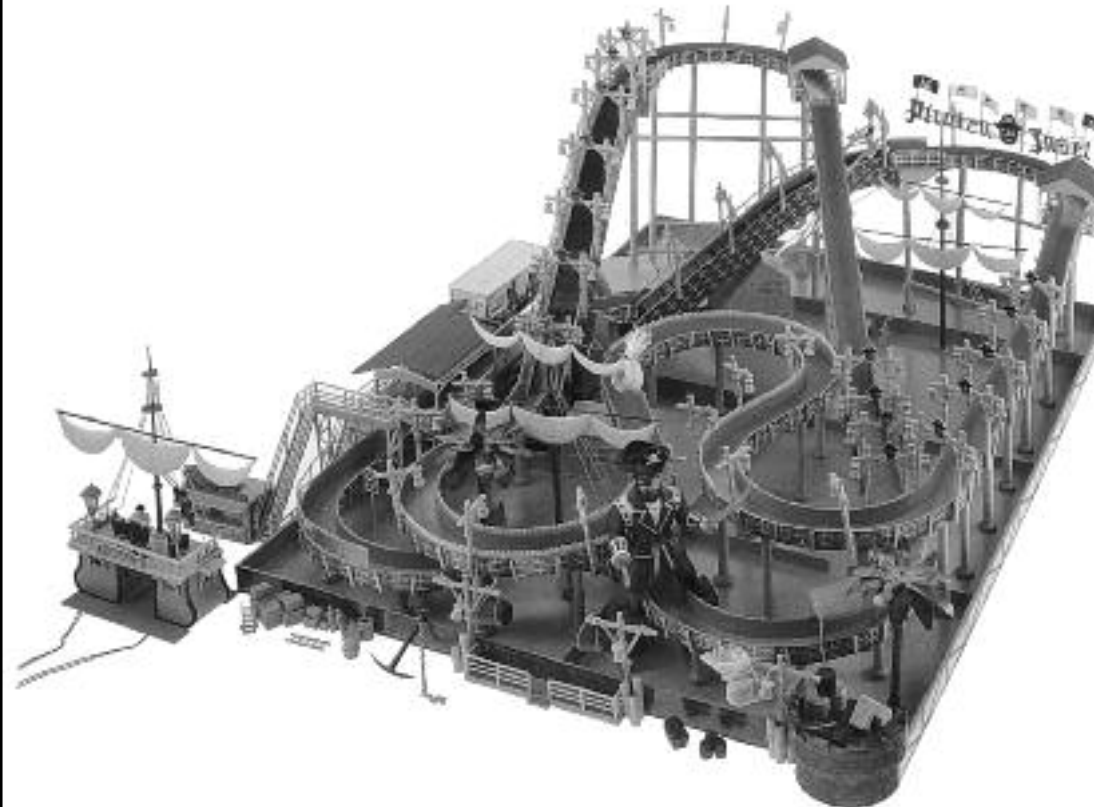

Inhalt	Spritzlinge	1	1	x	5	2	x	9	1	x	13	4	x	17	1	x	25	1	x
Contents	Sprues	2	1	x	7	1	x	10	1	x	14A	3	x	18	2	x	26	1	x
Contenu	Moulages	3	1	x	7	1	x	11	1	x	15	1	x	20	1	x	3151	1	x
Inhoud	Gietstukken	4	1	x	8	3	x	12	1	x	16	1	x	21	1	x			

Sa. Nr.
226 712 0

Fensterfolie

Schnittmusterfolie für Fenster vom Trägermaterial abziehen und auf die Fensterfolie mit gleicher Größe blasenfrei aufbringen **(ohne Klebstoff!)**. Die benötigten Fenster werden ausgeschnitten und **ohne Schnittmusterfolie** auf die Rückseite der Fensterrahmen geklebt (Position laut Anleitung).

Window foil

Pull off pattern sheet for windows from carrier and apply it, bubble-free, to the window foil of the same size **(without any glue)**. Cut out the required windows and glue them to the rear side of the window frame **without pattern sheet** (position as to instructions).

Feuillet transparent

Retirer la feuille matrice pour fenêtre du matériel support et l'appliquer sur la feuille-fenêtre de même dimension sans que des bulles ne se produisent **(sans colle)**. Découper le nombre de fenêtres nécessaires et les coller **sans la feuille** modèle sur l'arrière des dormant (position selon instructions).

Vensterfolie

Knippatroonfolie voor de ramen van schutblad afhalen en zonder blaasjes op het raam folie van dezelfde grootte aanbrengen **(niet lijmen!)**. De benodigde ramen worden uitgeknipt en **zonder de knippatroonfolie** op de achterzijde van de raamkozijnen gelijmd (positie volgens handleiding).

Fensterfolie Wildwasserbahn Pirateninsel
Art. Nr. 140430 Sa. Nr. 226 709 0

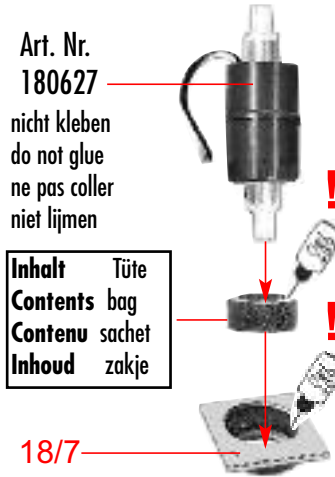
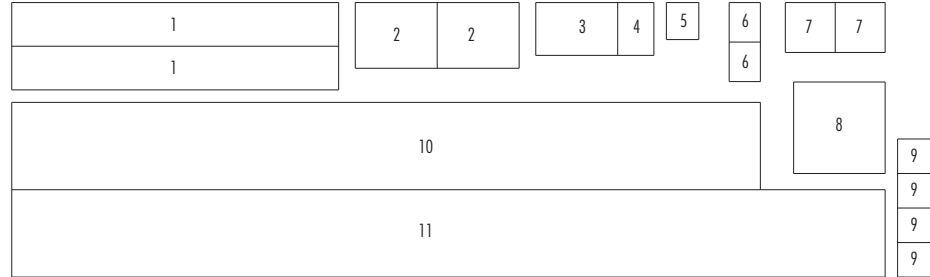

A 2 x

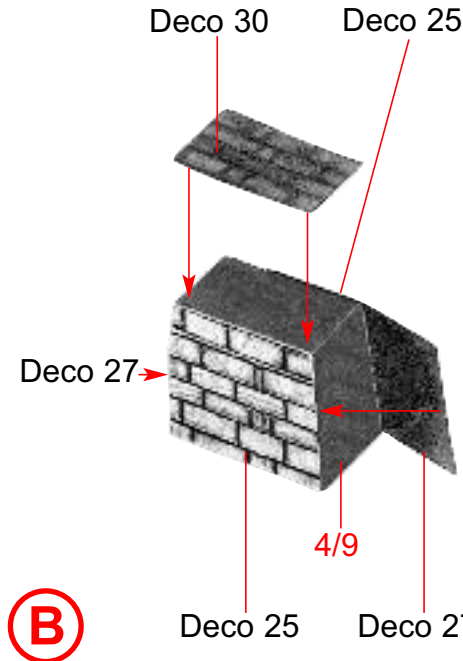

B

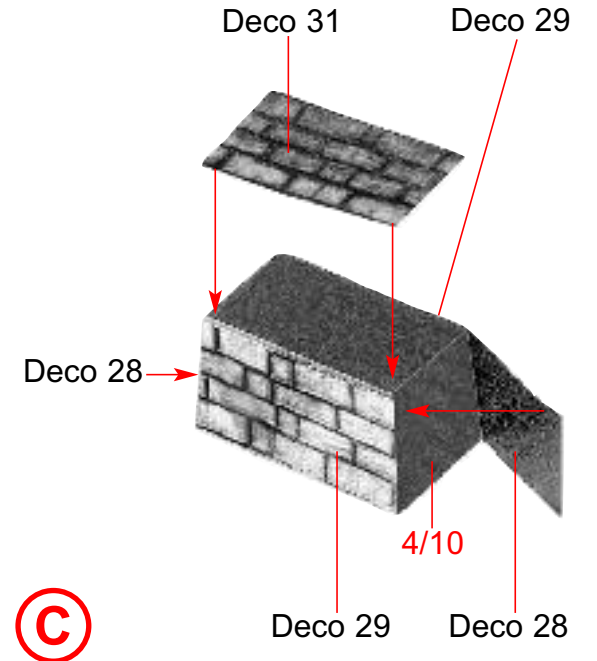

C

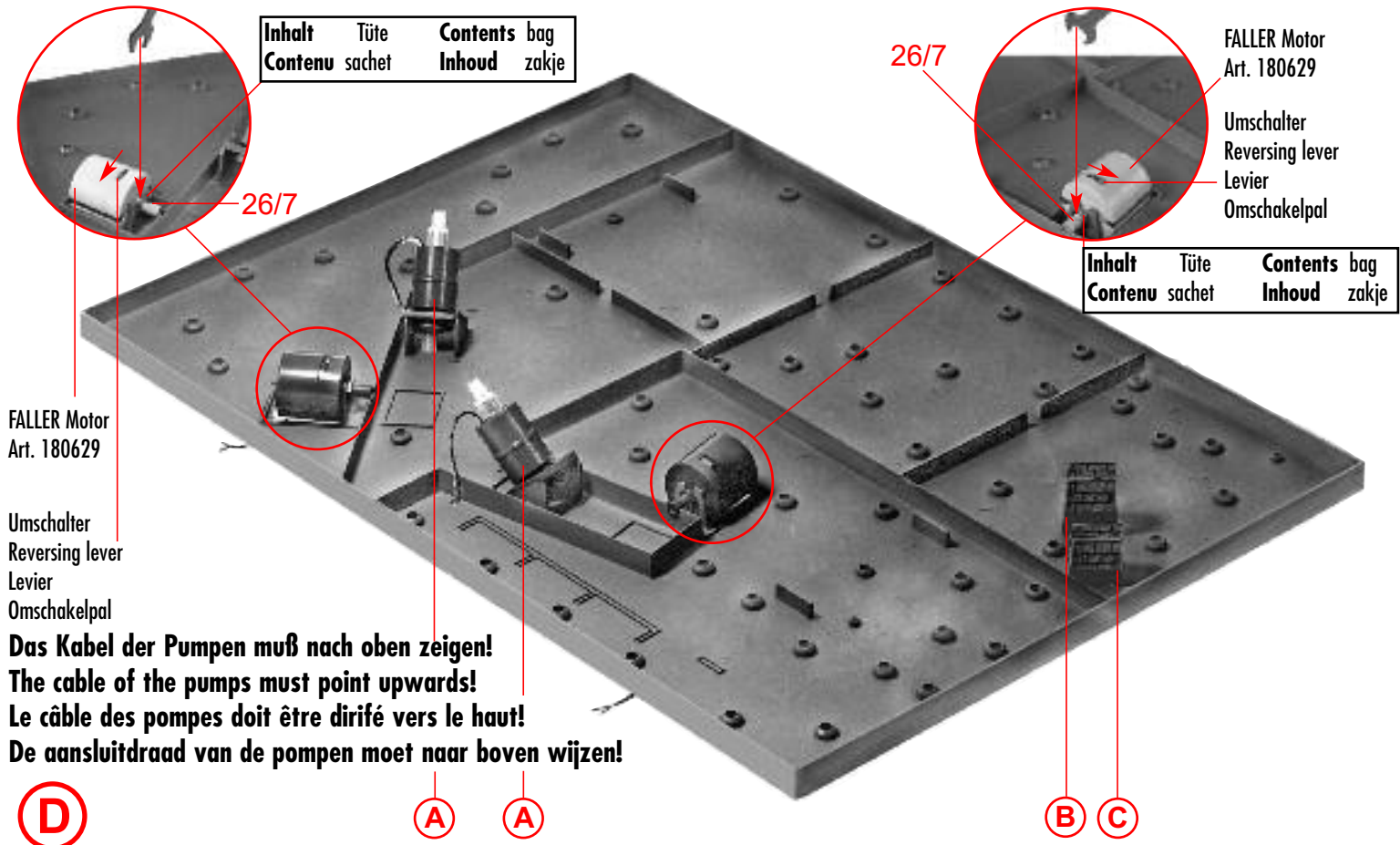

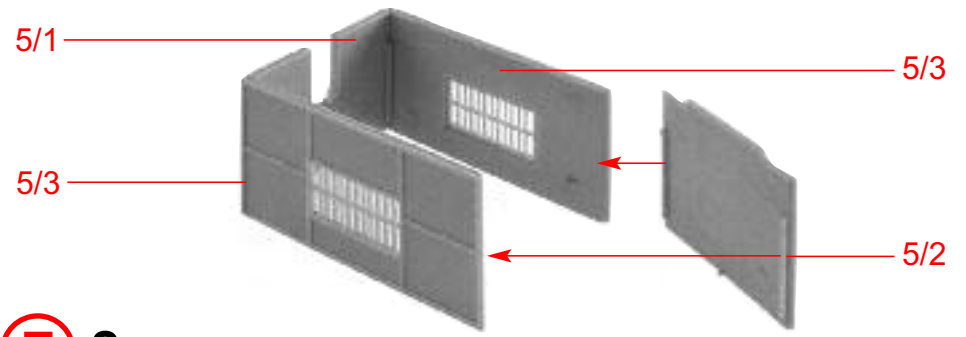

E 2 x



F

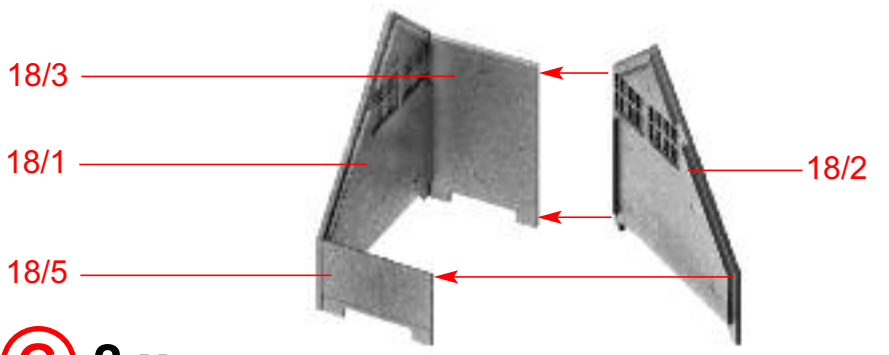

G 2 x

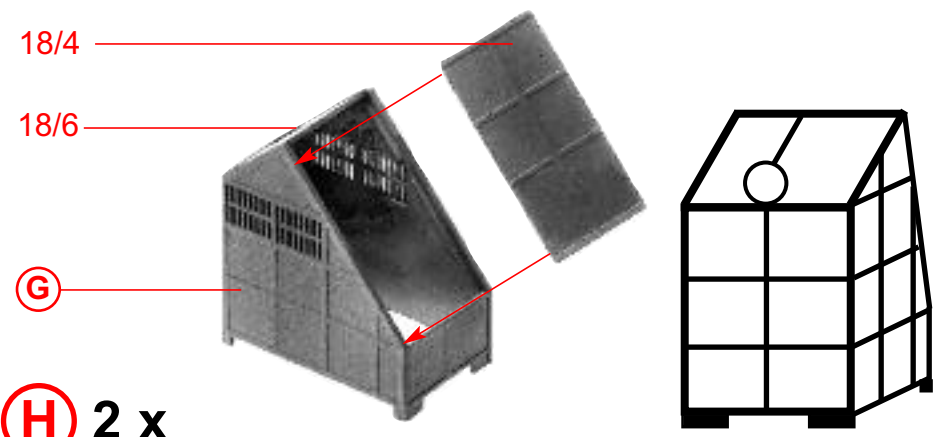

H 2 x

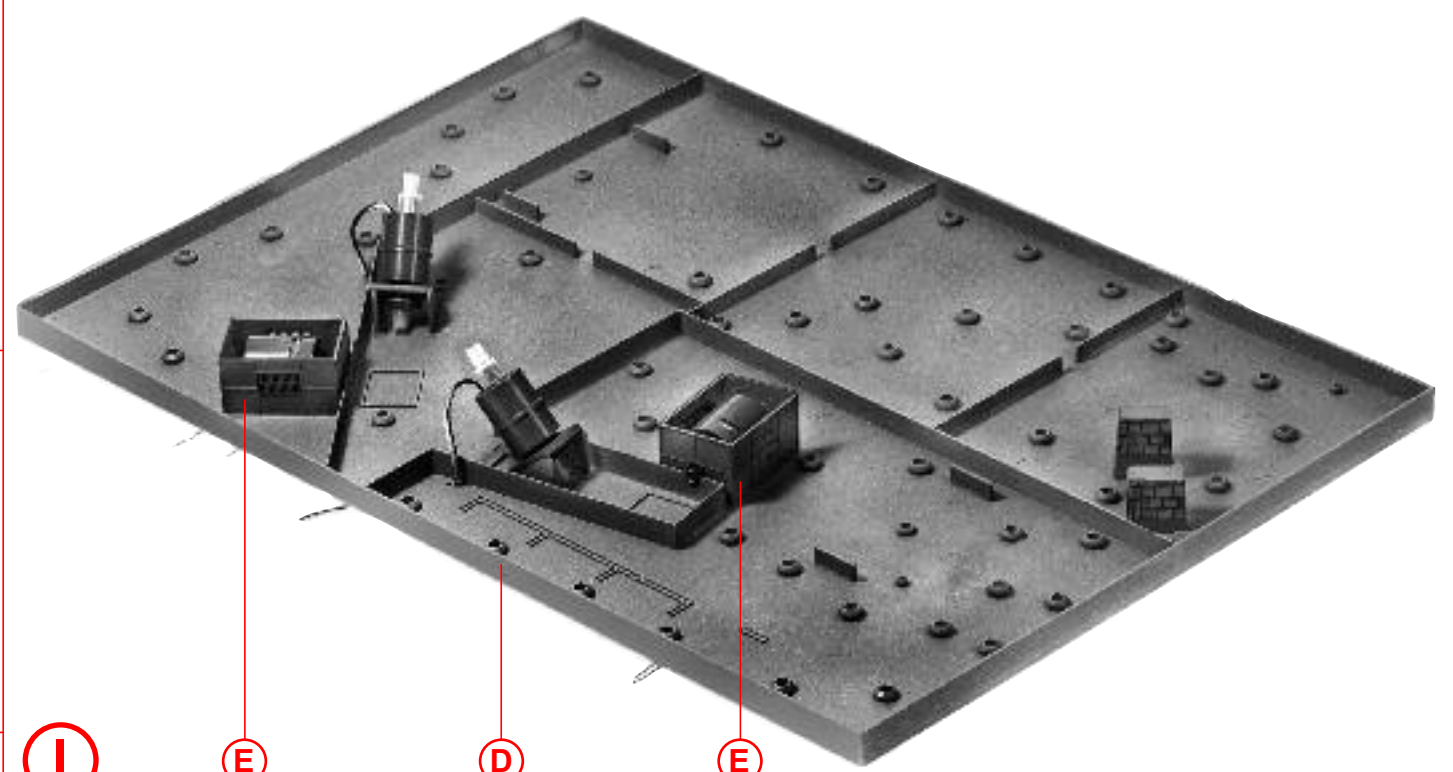

I

E

D

E

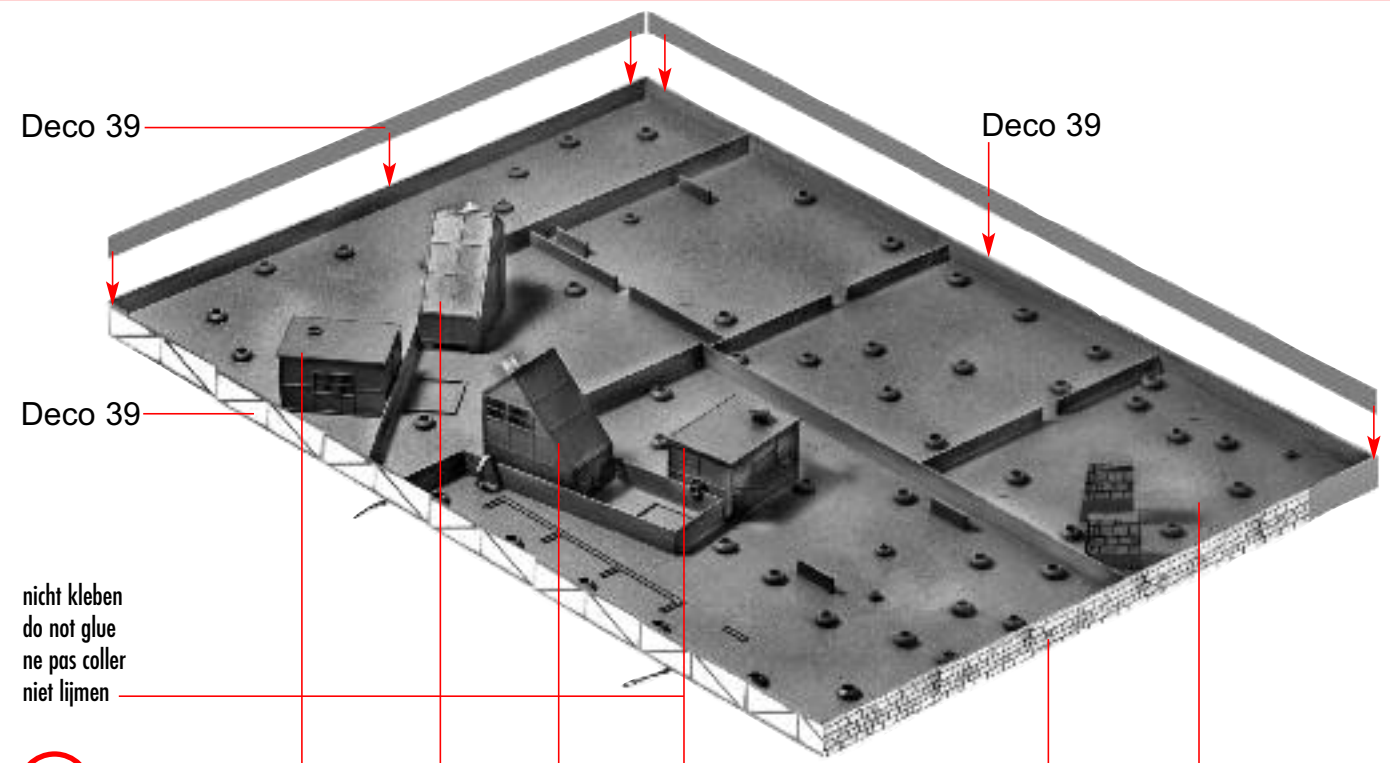

J

5/4

H

H

F

Deco 35

I

nicht kleben
do not glue
ne pas coller
niet lijmen

4

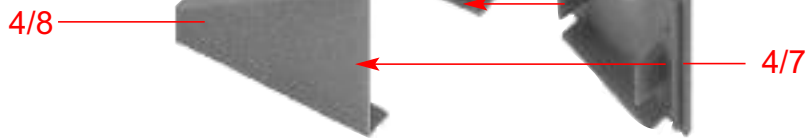

(K)

Hier eine durchgehende Klebnaht anbringen, um das Eindringen von Wasser zu vermeiden.

Apply a continuous glue seam here, so as to avoid the ingress of water.

Effectuer une couture collée de bout en bout pour empêcher une introduction d'eau.

Om binnendringen van water te voorkomen, moet hier een goed afsluitende lijmmaad worden aangebracht.

(L)

(M)

Deco 1

21/2

Deco 5

(N)

Deco 6

2/2

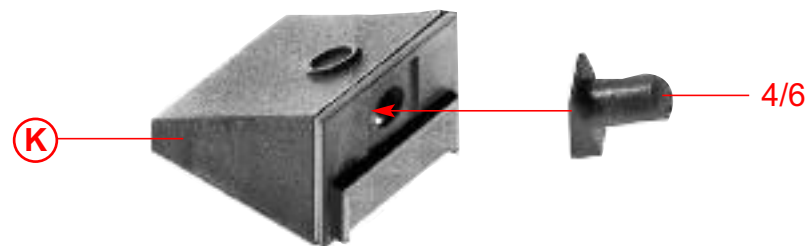

(L)

21/4

(O)

Deco 1

Deco 1



(D) Beim Zusammenkleben der einzelnen Fahrbahnteile darauf achten, daß die Teile auf Stoß bündig miteinander verklebt werden. Bitte die Teile gut entgraten, Übergangsstöße vermeiden, sauber und exakt arbeiten
Klebestellen gut abtrocknen lassen.

(GB) When you glue the individual track sections together, see to it that the joints are glued together, so that they are flush with each other. Deburr the parts well, avoid transition joints and work neatly and exactly.
Allow glued joints to dry well.

(F) En collant les différentes pièces de la voie, veiller à ce que les pièces soient assemblées à fleur. Bien ébarber les pièces, éviter des bords se chevauchant, travailler de façon propre et précise.
Laisser bien sécher les points de collage.

(NL) Let er op dat bij het tegen elkaar lijmen van de railstukken, deze delen nauwkeurig en strak tegen elkaar worden gelijmd. Verwijder alle gietgraten en door lijm veroorzaakte ribbels en werk netjes en heel precies.
Alle gelijmde punten goed laten drogen.

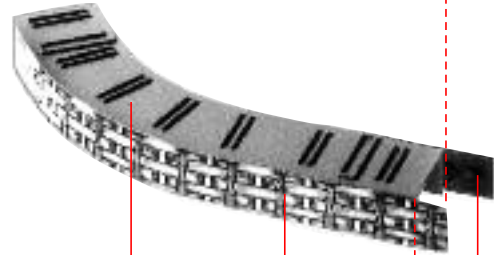

(P) 21/3 Deco 1 Deco 1

(Q)

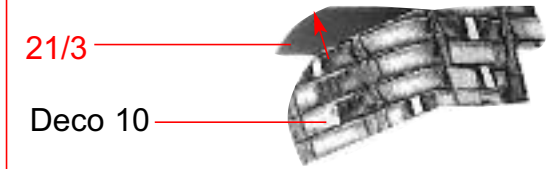
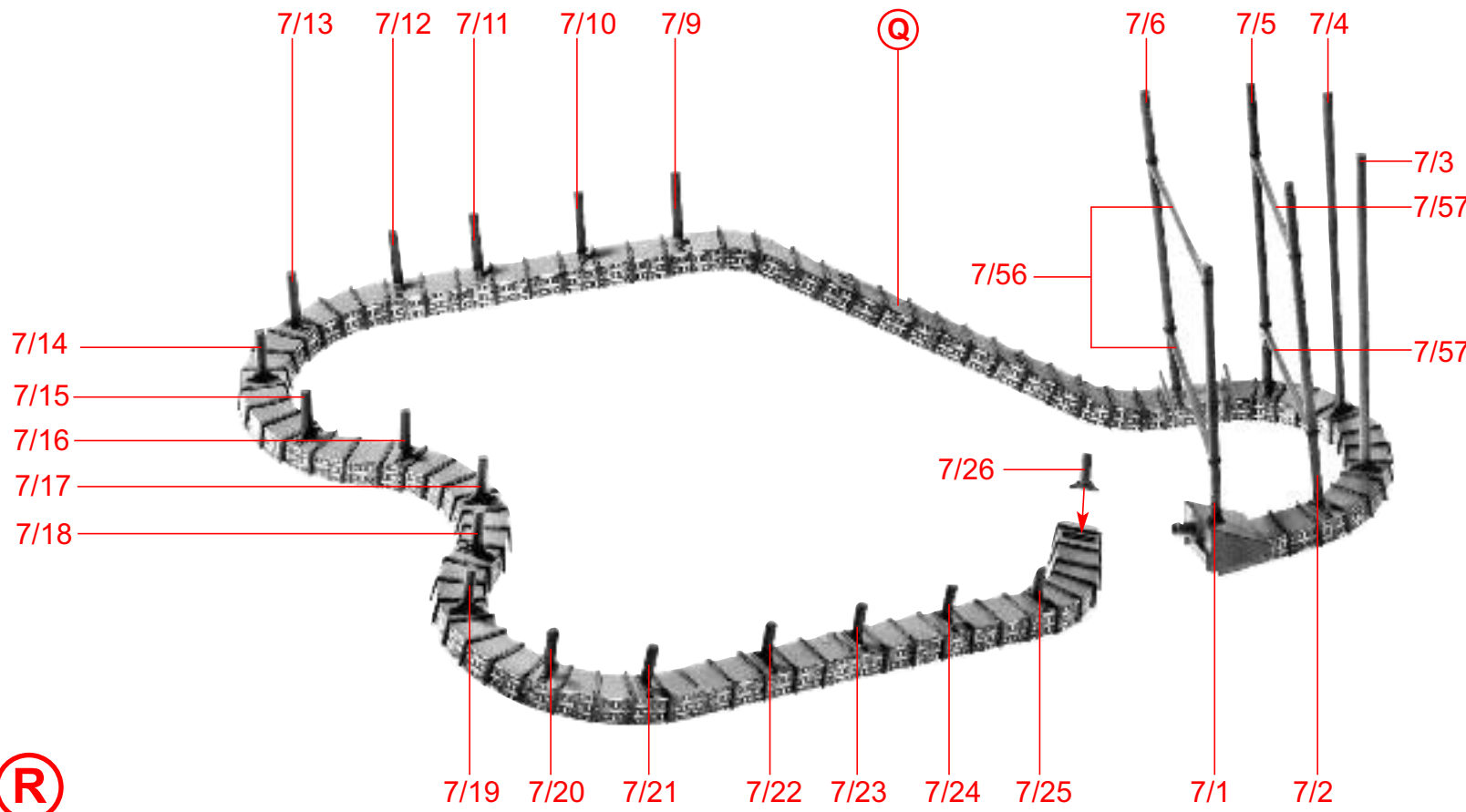
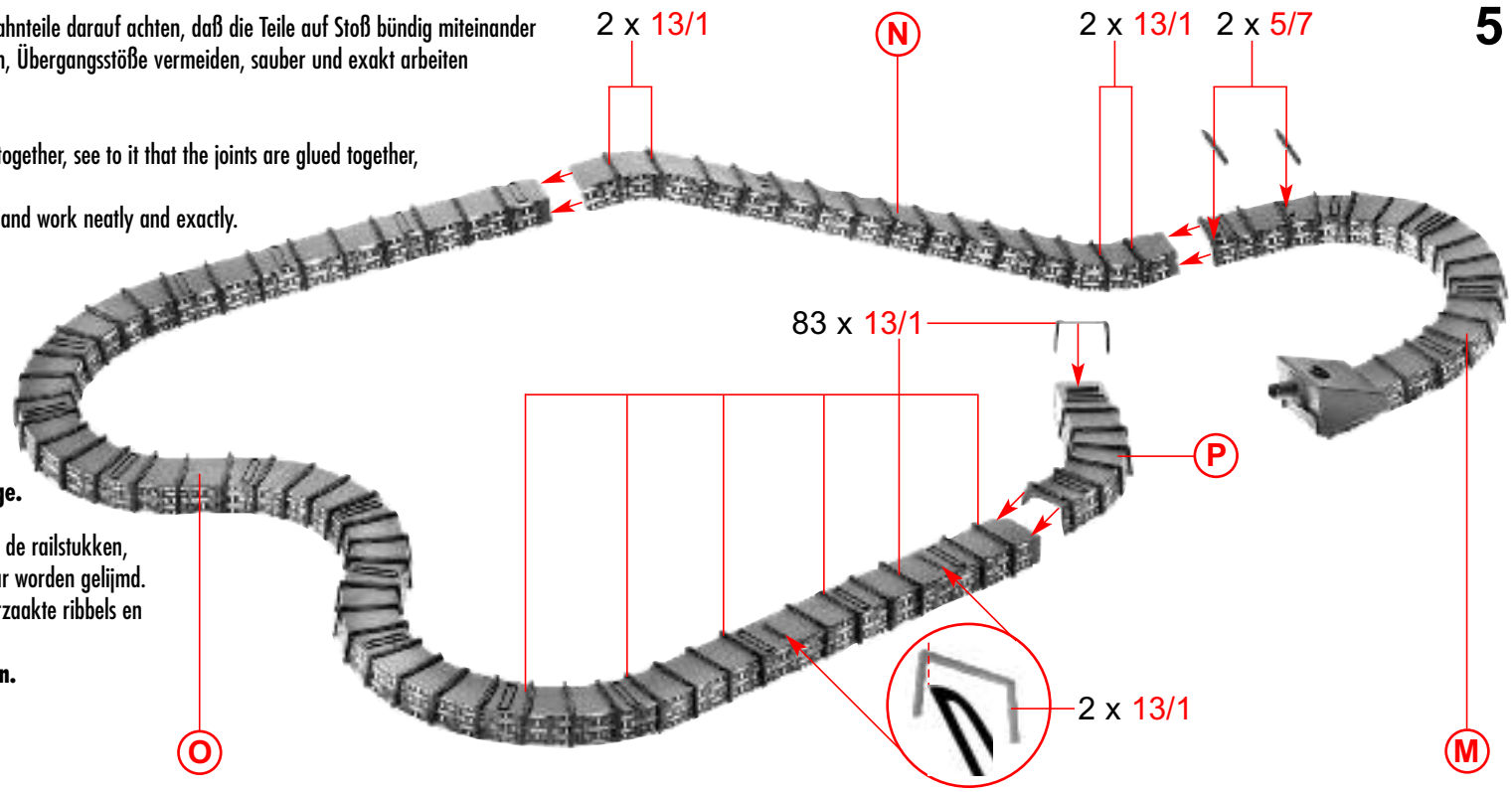

(S)



(T)

6

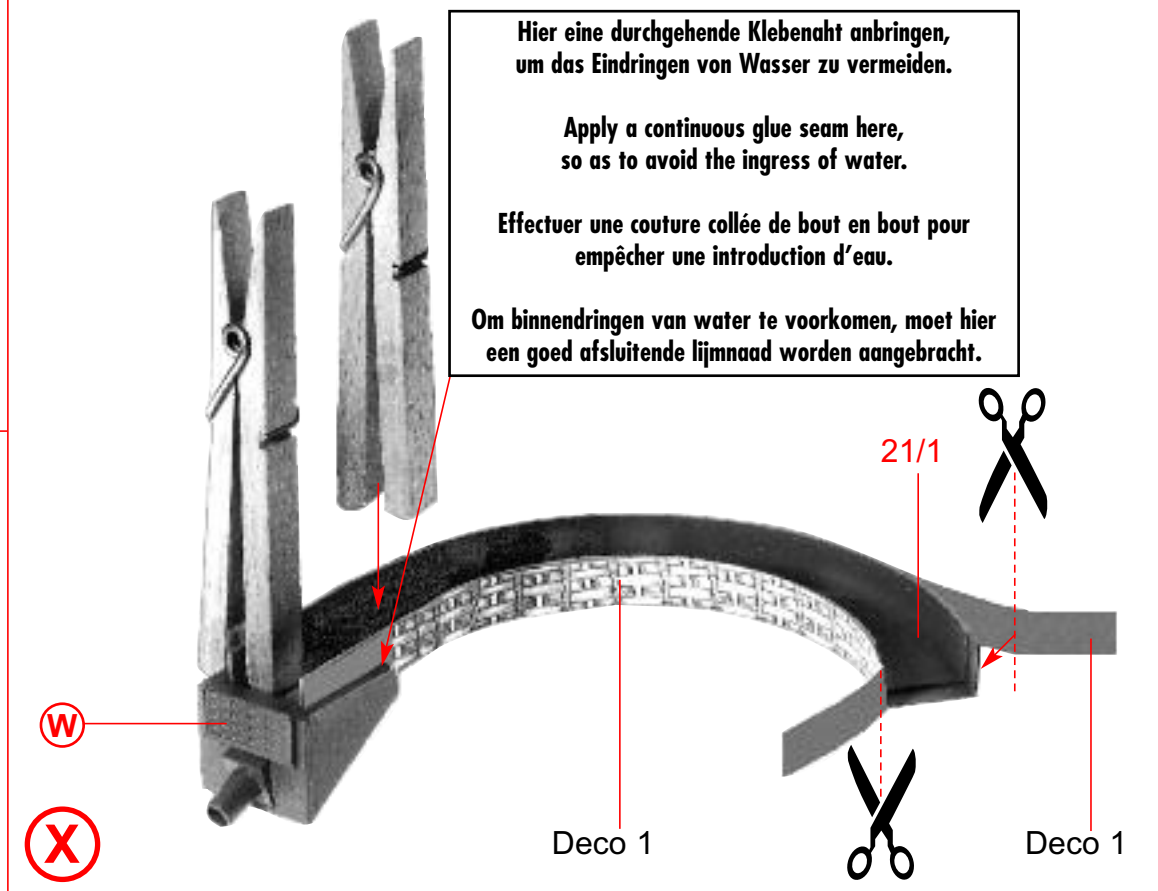
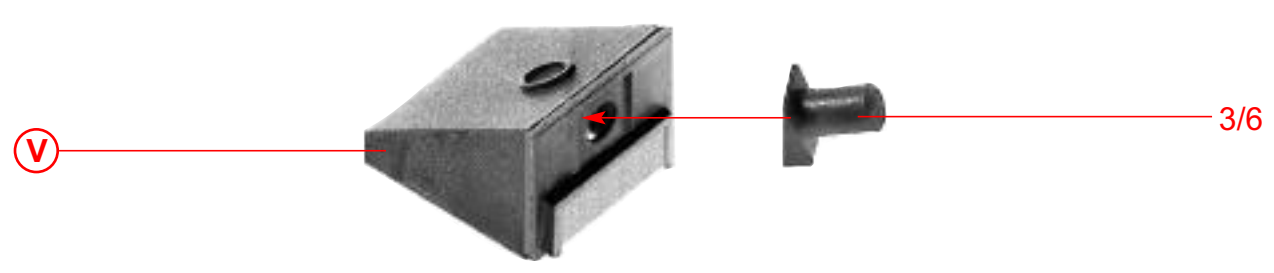
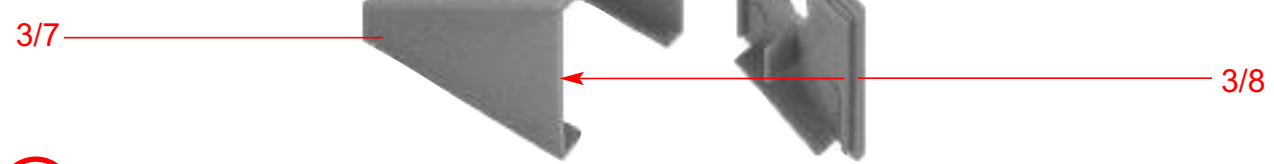
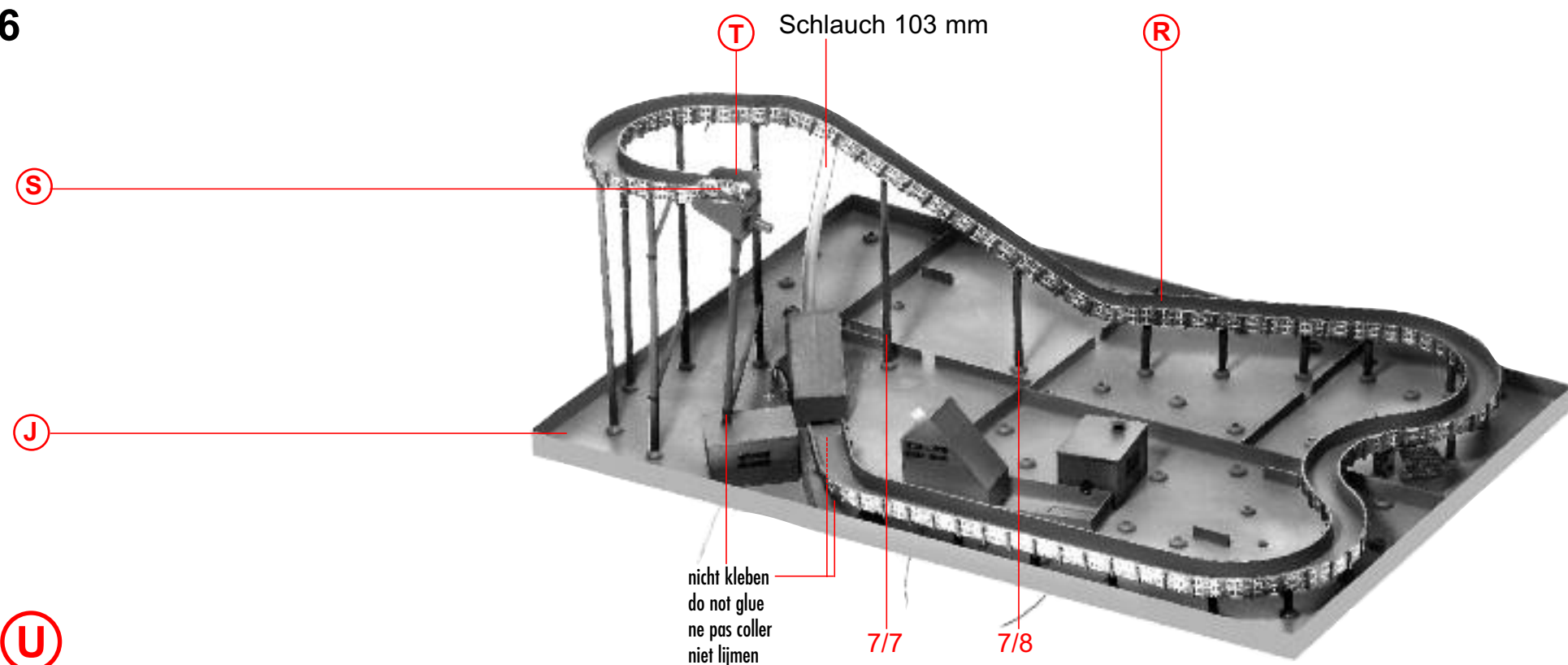

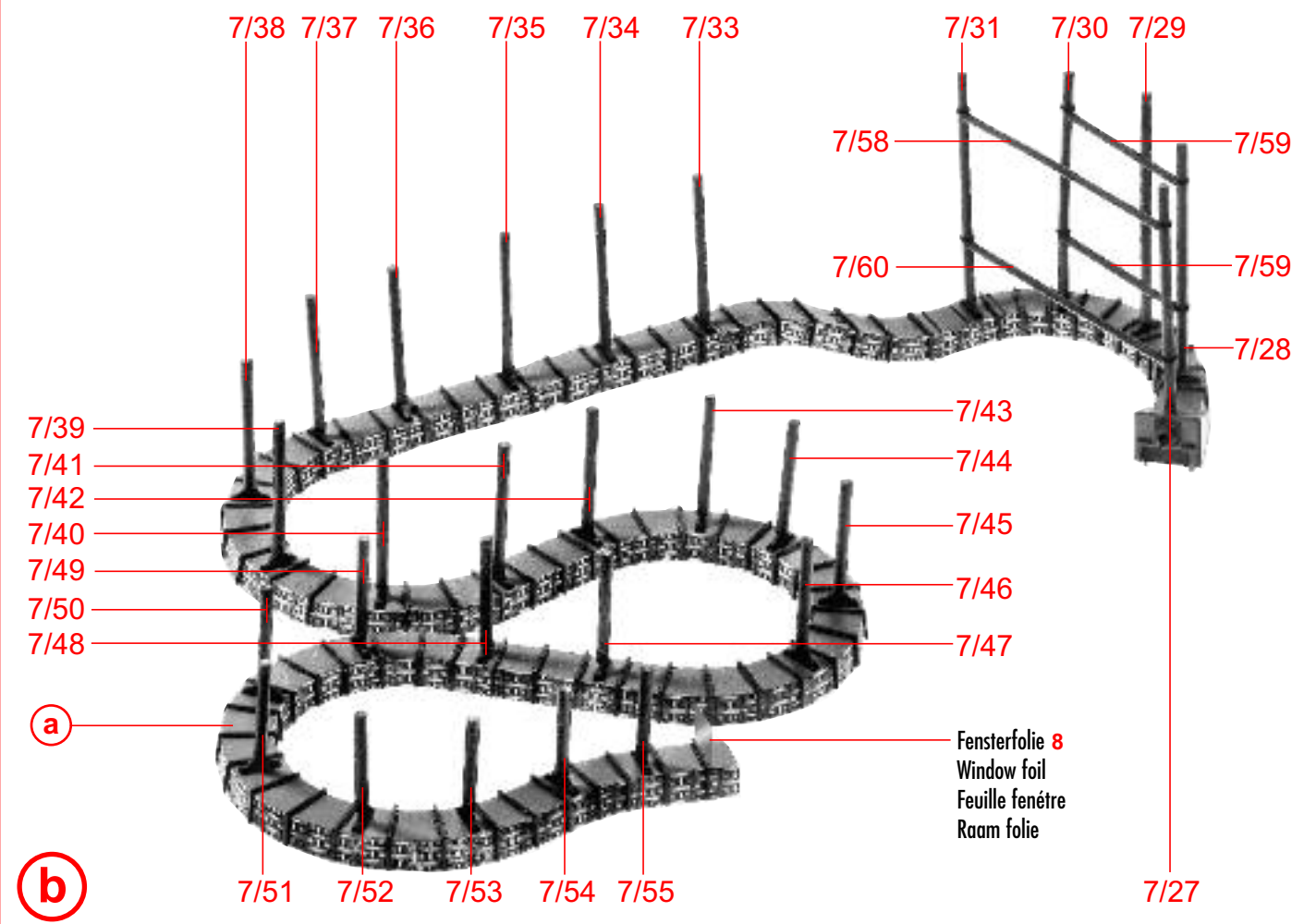
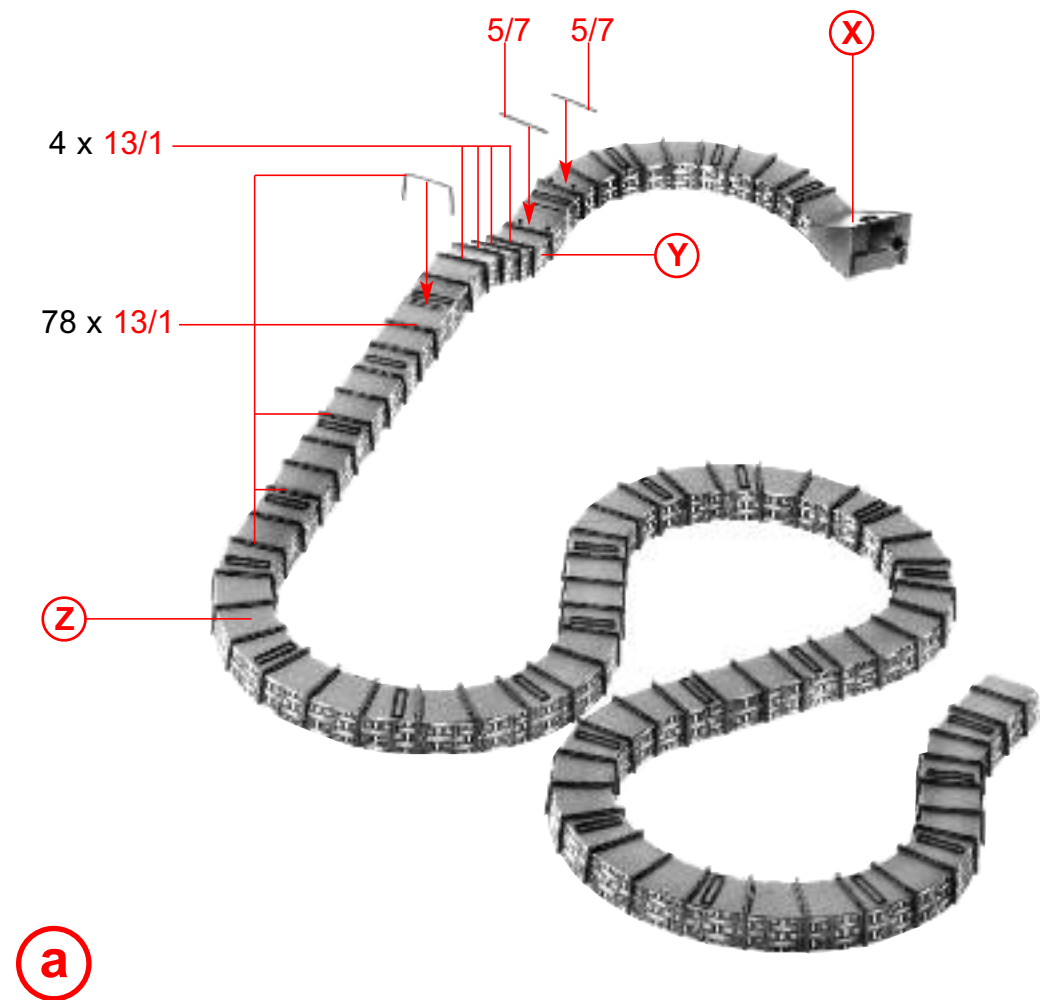
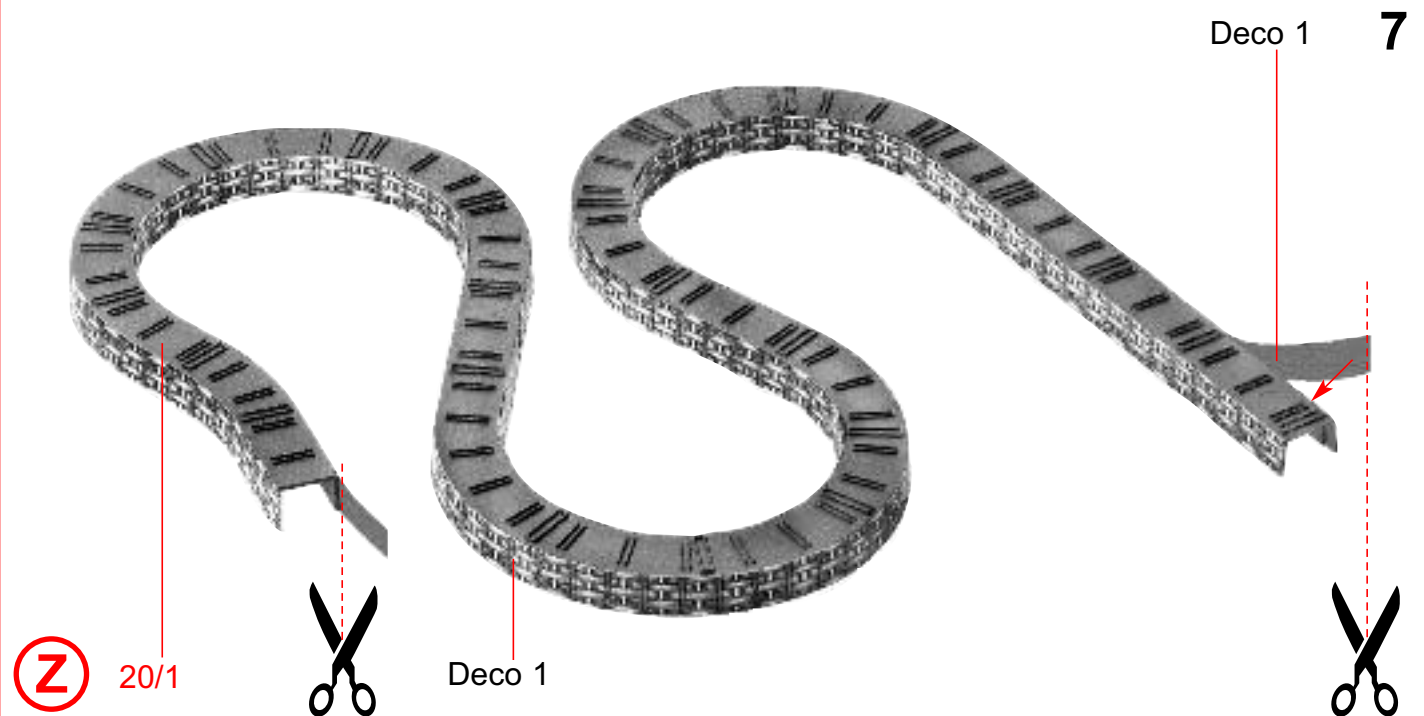
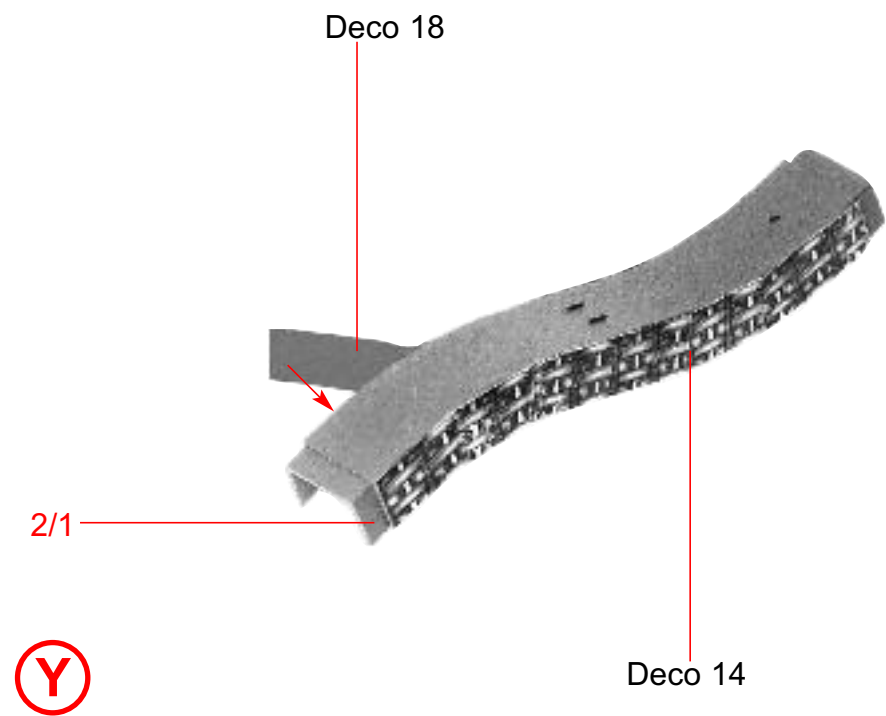

8

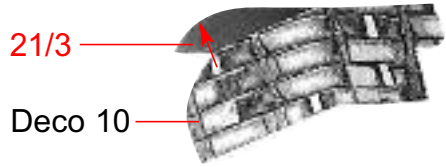

c



d

nicht kleben
do not glue
ne pas coller
niet lijmen

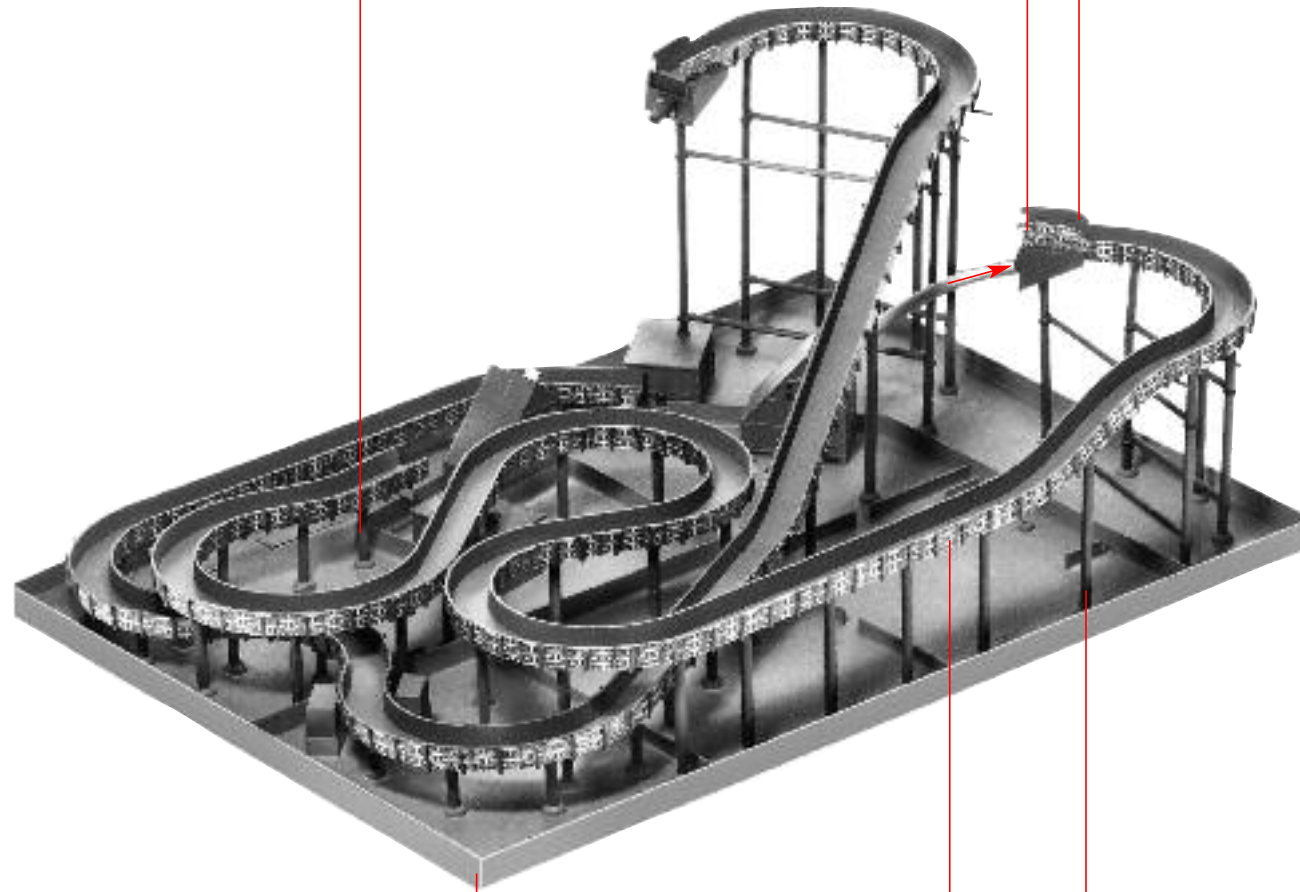

e

u

b

7/32

d c

8/8



f 24 x

8/10

Deco 36

8/15

f

8/1

g 12 x

f

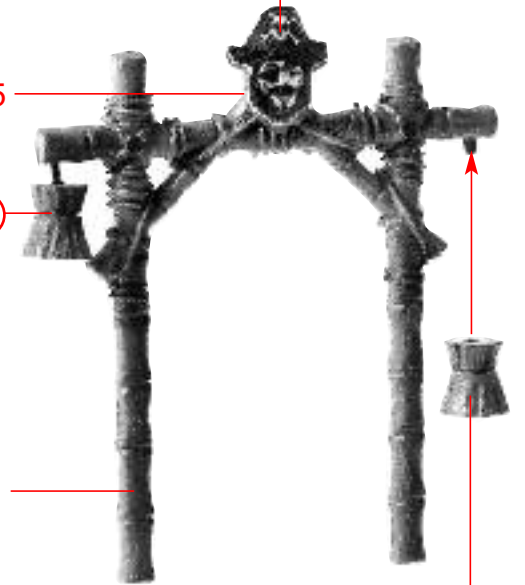

Sekundenkleber verwenden.
Use instant modelling cement.
Utilisez la colle rapide.
Gebruik seconden-lijm.

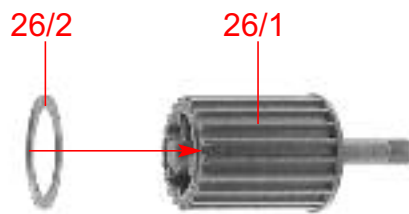

h 2 x

Sekundenkleber verwenden.
Use instant modelling cement.
Utilisez la colle rapide.
Gebruik seconden-lijm.

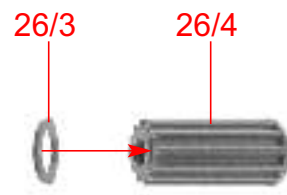

i 2 x

Inhalt Tüte
Contents bag
Contenu sachet
Inhoud zakje

26/6



nicht kleben
do not glue
ne pas coller
niet lijmen

j 4 x

Inhalt Tüte
Contents bag
Contenu sachet
Inhoud zakje

i

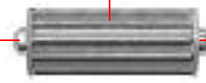

nicht kleben
do not glue
ne pas coller
niet lijmen

k 2 x

nicht kleben
do not glue
ne pas coller
niet lijmen

26/5

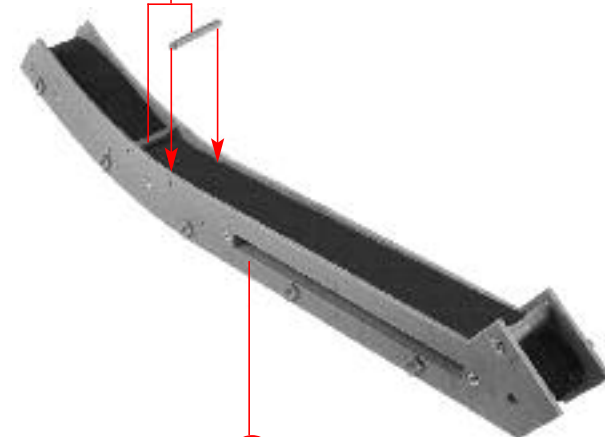

o

n

nicht kleben
do not glue
ne pas coller
niet lijmen

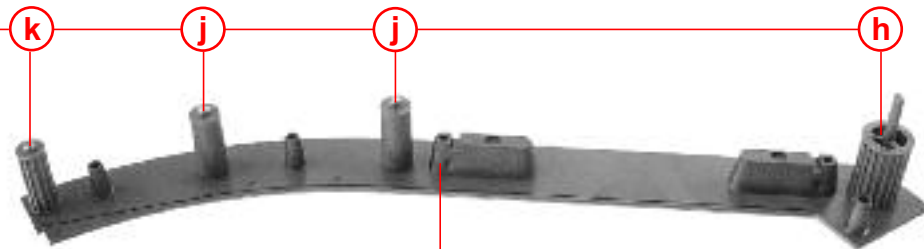

25/3

l

nicht kleben
do not glue
ne pas coller
niet lijmen

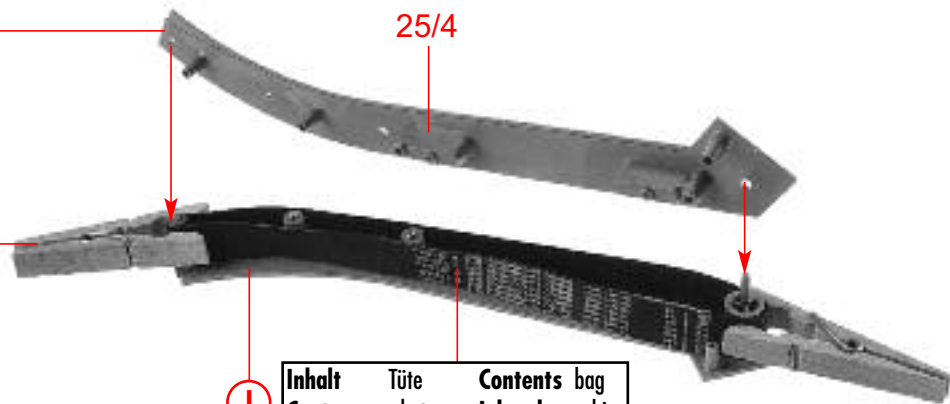

25/4

liegt nicht bei
not included
non jointe
niet bijgevoegd

m

Inhalt Tüte
Contents bag
Contenu sachet
Inhoud zakje

nicht kleben
do not glue
ne pas coller
niet lijmen

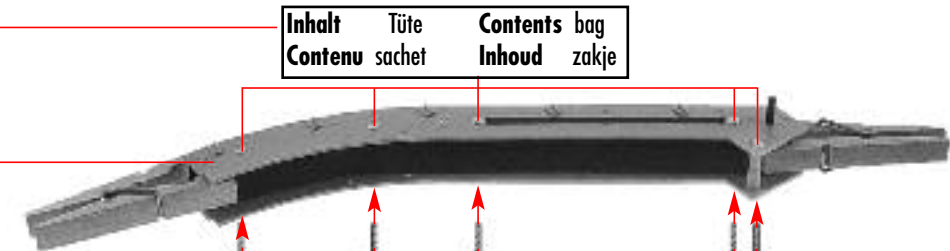

Inhalt Tüte
Contents bag
Contenu sachet
Inhoud zakje

n

Inhalt Tüte
Contents bag
Contenu sachet
Inhoud zakje

nicht kleben
do not glue
ne pas coller
niet lijmen

Deco 44

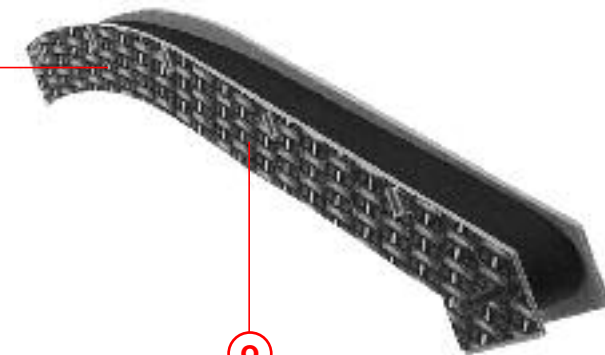

p

o

nicht kleben
do not glue
ne pas coller
niet lijmen

Fensterfolie
Window foil
Feuillet transparent
Vensterfolie

18.7 mm

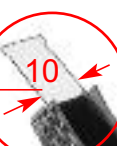

10

Deco 45

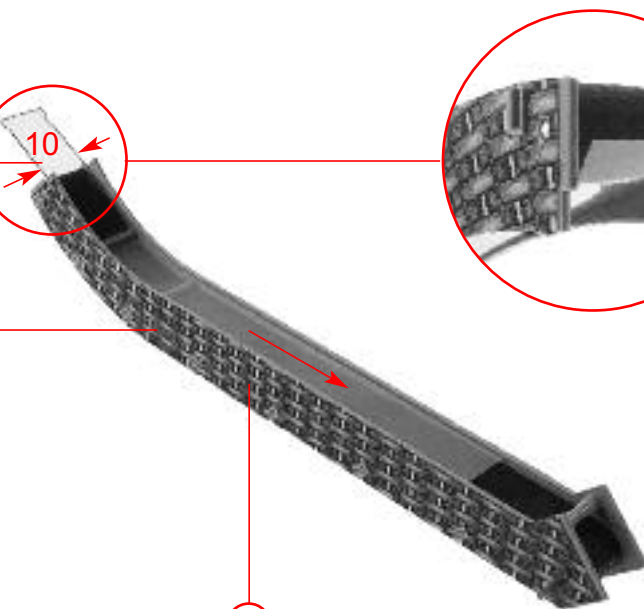

q

p

10

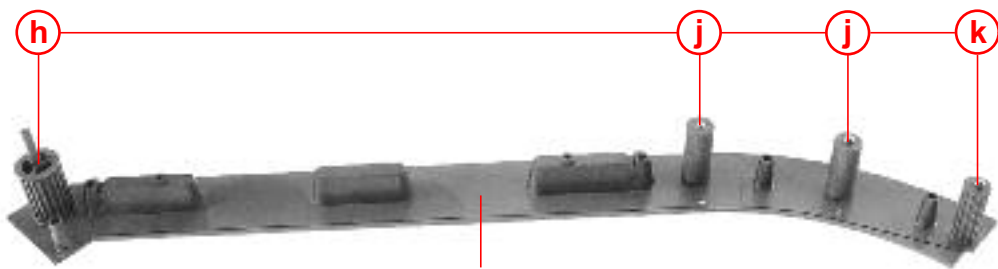

nicht kleben
do not glue
ne pas coller
niet lijmen

r

25/1

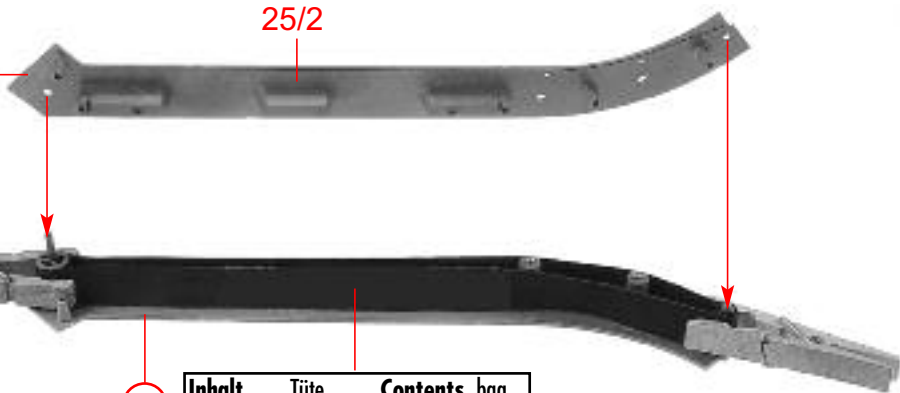

nicht kleben
do not glue
ne pas coller
niet lijmen

liegt nicht bei
not included
non jointe
niet bijgevoegd

s

r

Inhalt Tüte Contents bag
Contenu sachet Inhoud zakje

nicht kleben
do not glue
ne pas coller
niet lijmen

s

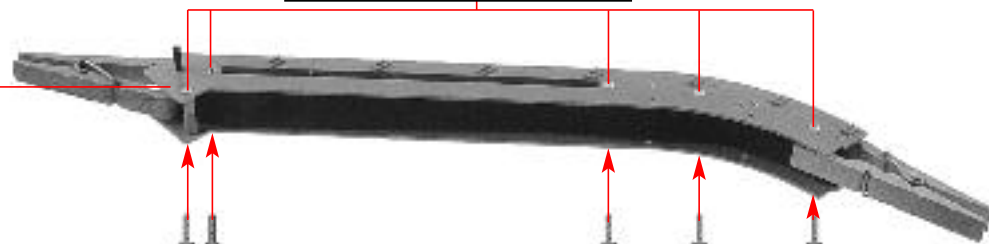

Inhalt Tüte Contents bag
Contenu sachet Inhoud zakje

nicht kleben
do not glue
ne pas coller
niet lijmen

t

Inhalt Tüte Contents bag
Contenu sachet Inhoud zakje

nicht kleben
do not glue
ne pas coller
niet lijmen

26/5

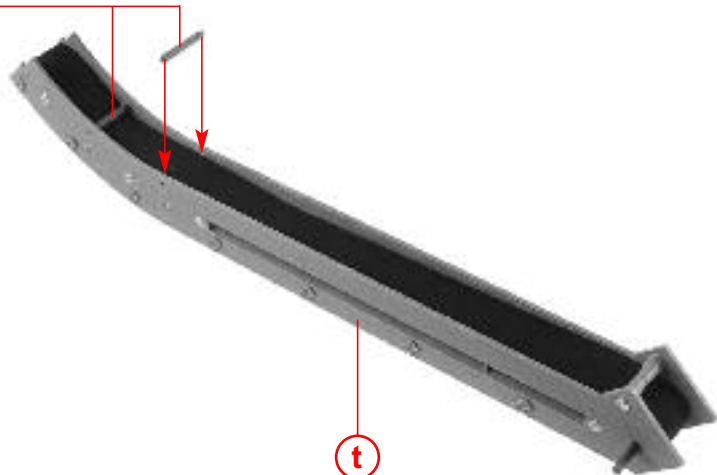

u

t

Deco 43

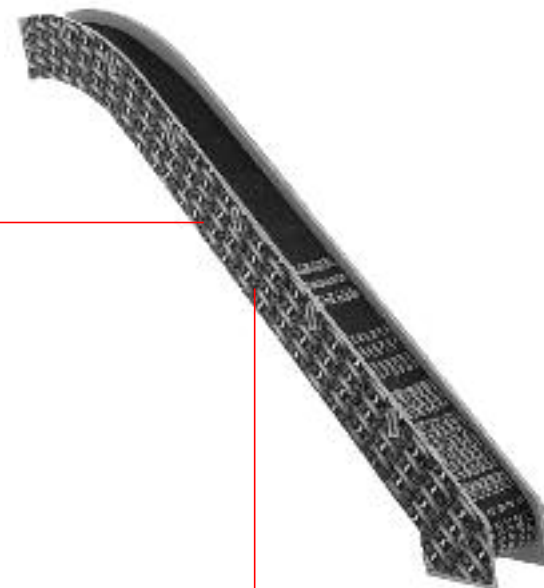

v

u

nicht kleben
do not glue
ne pas coller
niet lijmen

Fensterfolie 18.7 mm
Window foil
Feuillet transparent
Vensterfolie

Deco 42

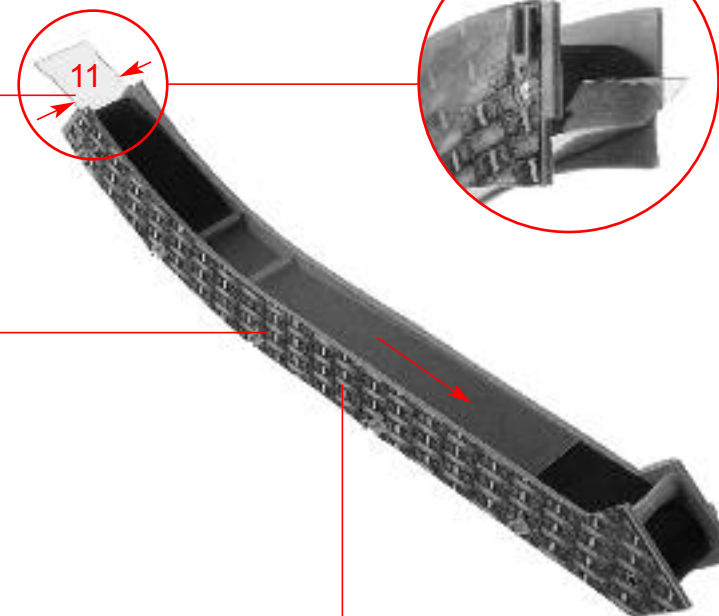

w

v

Fahrbahn und Förderbandgestell sollten leicht gegeneinander drücken, damit an dieser Stelle kein Wasser austreten kann!

Race track and conveyor belt stand should contact each other slightly, so that water cannot emerge at this point!

La chaussée et le bâti du convoyeur devraient être en contact ferme, pour éviter une sortie de l'eau!

Vaargoot en transportbandstelling moeten licht tegen elkaar worden aangedrukt, zodat er op deze plaatsen geen water kan uitlopen!

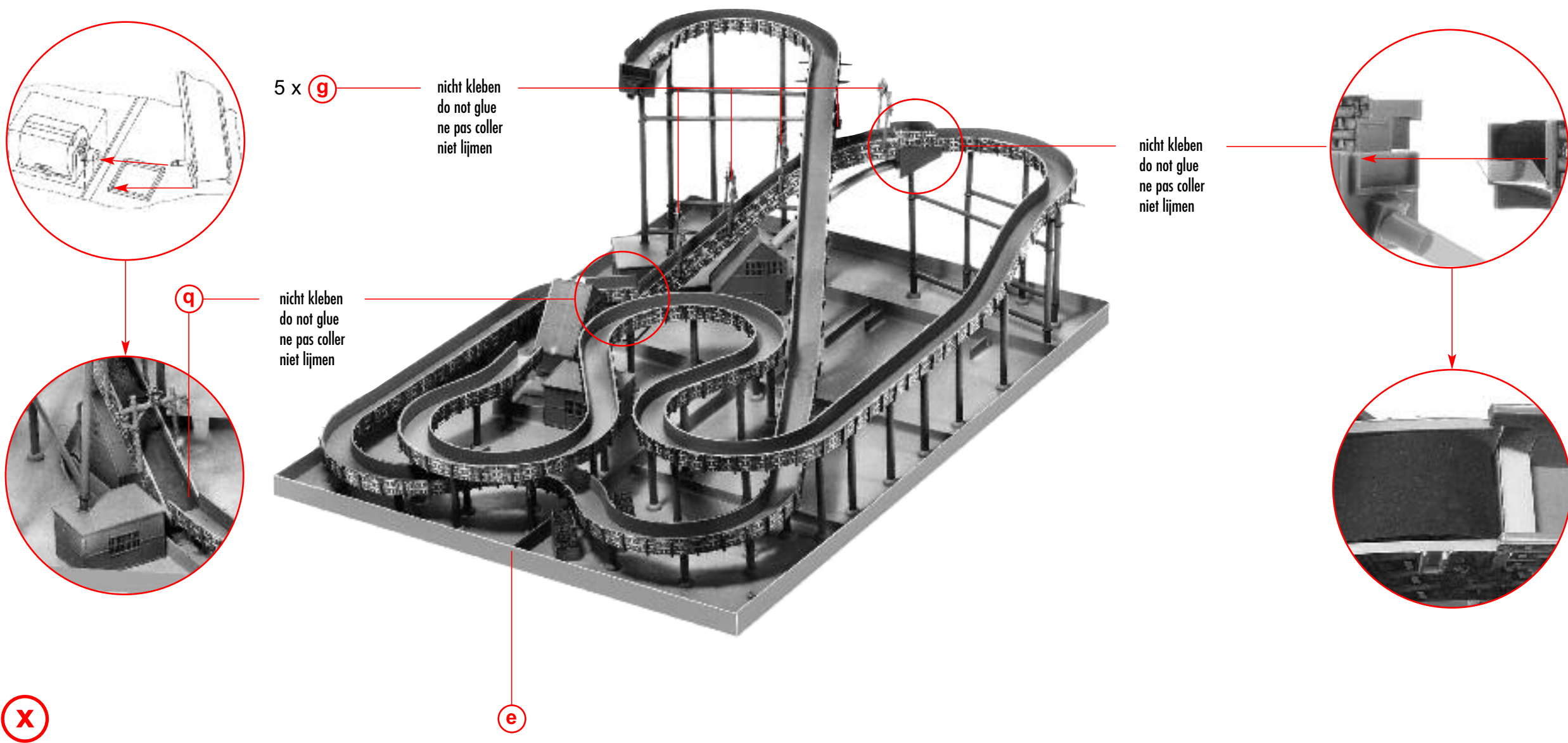

Fahrbahn und Förderbandgestell sollten leicht gegeneinander drücken, damit an dieser Stelle kein Wasser austreten kann!

Race track and conveyor belt stand should contact each other slightly, so that water cannot emerge at this point!

La chaussée et le bâti du convoyeur devraient être en contact ferme, pour éviter une sortie de l'eau!

Vaargoot en transportbandstelling moeten licht tegen elkaar worden aangedrukt, zodat er op deze plaatsen geen water kan uitlopen!

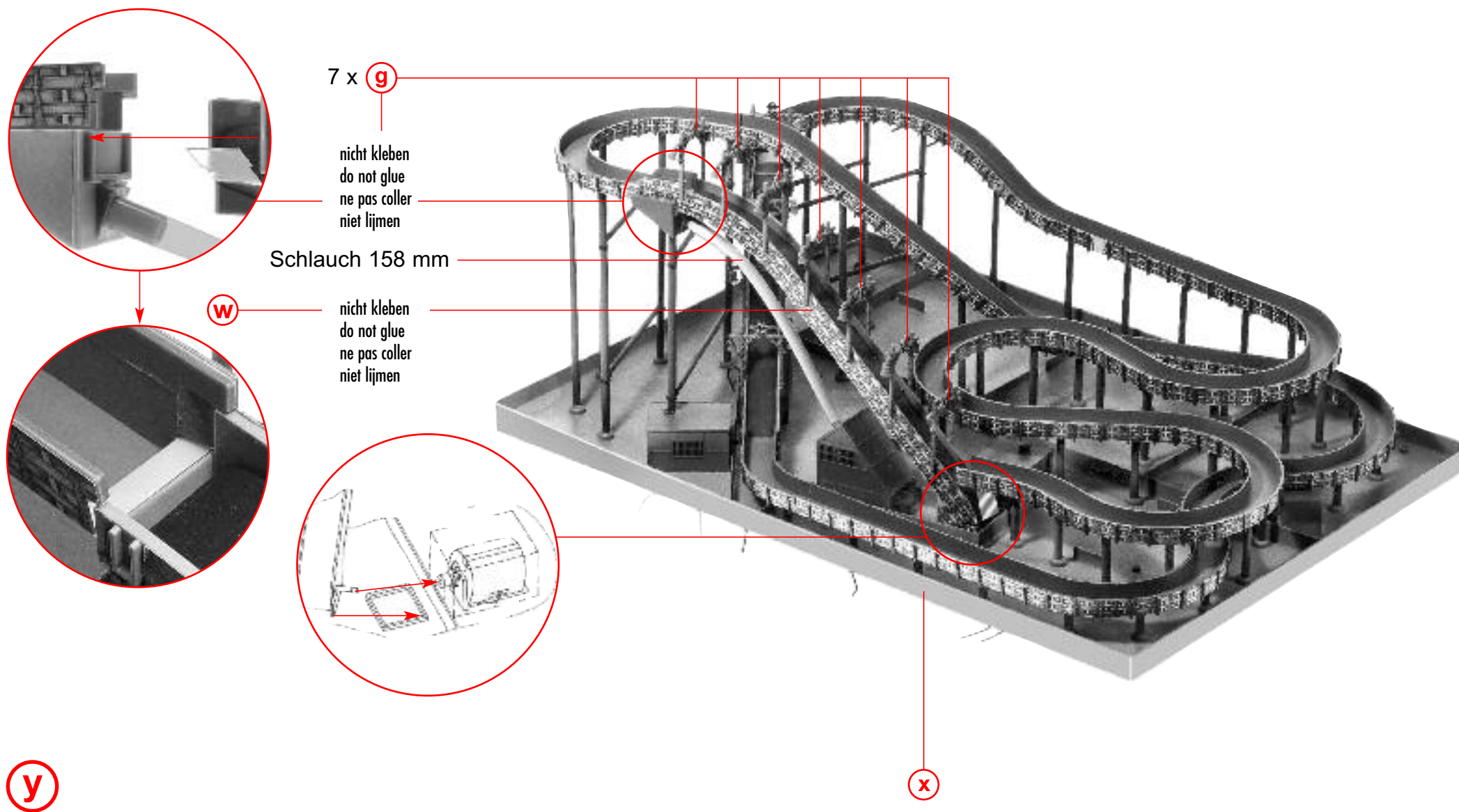

Hier eine durchgehende Klebnaht anbringen, um das Eindringen von Wasser zu vermeiden.

Apply a continuous glue seam here, so as to avoid the ingress of water.

Effectuer une couture collée de bout en bout pour empêcher une introduction d'eau.

Om binnendringen van water te voorkomen, moet hier een goed afsluitende lijmmaad worden aangebracht.

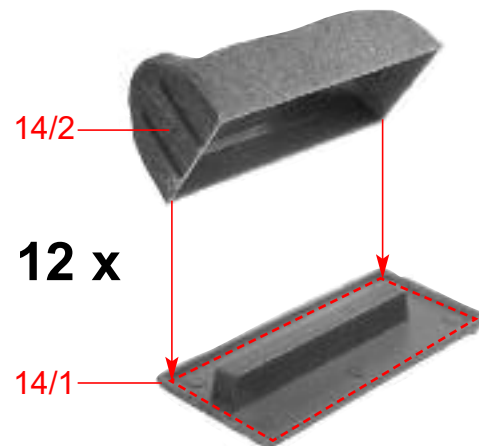

8 mm

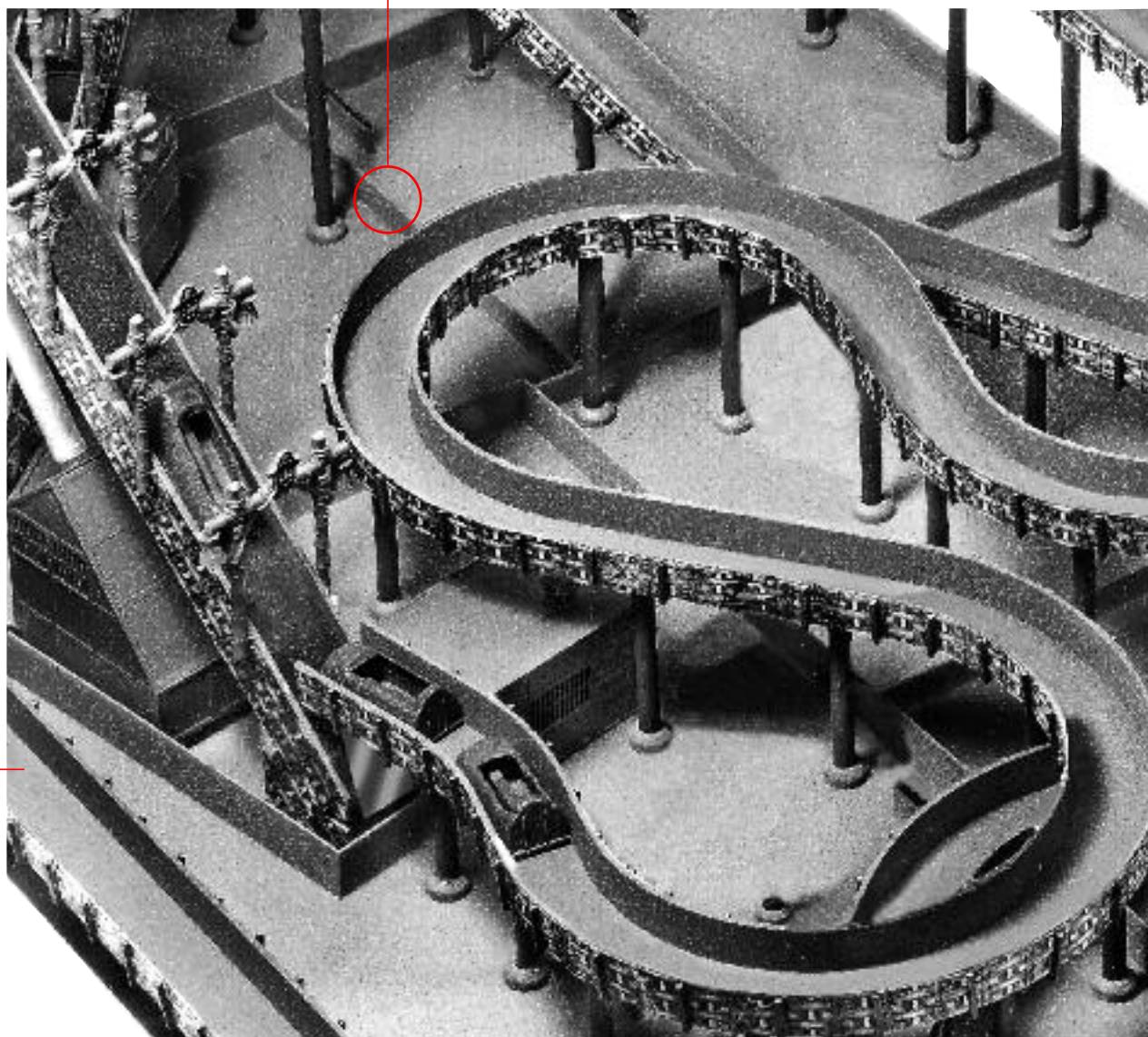

Füllen Sie Wasser in die Bodenplatte ein, aber nur in das Feld, in dem sich die Pumpen befinden.
ACHTUNG: benutzen Sie kein destilliertes und kein Leitungswasser (Verkalkungsgefahr). Bitte nur Tafelwasser ohne Kohlensäure verwenden!

Das Wasser sollte bis an die Oberkante der 8 mm hohen Rippen reichen. Dann schließen Sie die zwei Motoren (Art. 180629) und die zwei Pumpen (Art. 180627) an Ihren Trafo (16 V, Wechselspannung) an.

Wenn die Fließbänder und die Pumpen störungsfrei laufen, können Sie die Fahrzeuge in die Fahrbahn einsetzen. Sie sollten den Probelauf sorgfältig und ausgiebig (ca. 1 Stunde) vornehmen, bevor Sie den Bau des Modells fortsetzen.

Es empfiehlt sich zur Fertigstellung des Modells das Wasser aus der Bodenplatte wieder zu entleeren.

Fill water into the field of the baseplate in which the pumps are located.

Attention: do not use distilled water or tap water (calcification risk).

Only use table water without carbonic acid.

The water should reach up to the top edge of the 8 mm high ribs.

Then connect the two motors (Art. 180629) and the two pumps (Art. 180627) to your transformer (16 V AC). If the conveyor belts and the pumps run properly, you can place the vehicles onto the track. The test run should be made carefully and for an extended period of time (approx. one hour) before you go on building your model. For completion of the model, it is recommended to drain the water from the baseplate again.

Introduire l'eau dans la plaque de fond, mais uniquement dans le compartiment dans lequel se trouvent les pompes.

ATTENTION : ne pas utiliser d'eau distillée ou du robinet (risque d'entartrage).

N'utiliser que de l'eau en bouteille sans gaz carbonique.

L'eau doit atteindre le bord supérieur des nervures d'une hauteur de 8 mm.

Brancher ensuite les deux moteurs (art. 180629) et les deux pompes (art. 180627) sur votre trafo (16 V c.a.). Des que les convoyeurs et les pompes fonctionnent normalement, vous pouvez placer les véhicules sur la chaussée. La marche d'essai doit être effectuée soigneusement et pendant env. 1 heure, avant de continuer le montage du modèle.

Il est recommandé d'enlever l'eau de la plaque de fond pour achever le modèle.

Giet water in het bodemreservoir, maar alleen daar, waar de pompen zijn geplaatst.

LET OP: gebruik geen gedistilleerd water en geen leidingwater (gevaar voor kalk).

S.v.p. alleen tafelwater zonder koolzuur gebruiken.

Het water moet reiken tot de bovenkant van de 8 mm hoge randen!

Sluit daarna de twee motoren (nr. 180629) en de twee pompen (nr. 180627) aan op de trafo (16 V, wisselstroom). Als de transportbanden en de pompen zonder storingen werken, kunnen de voertuigen in de vaargoot worden gezet. De proefvaart moet nauwkeurig en langdurig (ongeveer 1 uur) worden uitgevoerd voordat verder aan de bouw van het model kan worden gewerkt. Het is raadzaam pas verder te bouwen na het leeggieten van de bodemplaat.

14

Inhalt	Tüte	Contents	bag
Contenu	sachet	Inhoud	zakje

Faden 200 mm
 Cord
 Aiguillée
 Garen

Faden verknoten und den Knoten mit Sekundenkleber fixieren!

Knot the thread and fix the thread with instand cement!

Nouer le fil et renforcer le noeud avec une goutte de colle rapide!

Draad vastknopen en de knoop met secondenlijm fixeren!



(A) 4 x

11/6

11/11

11/10

11/9

11/4

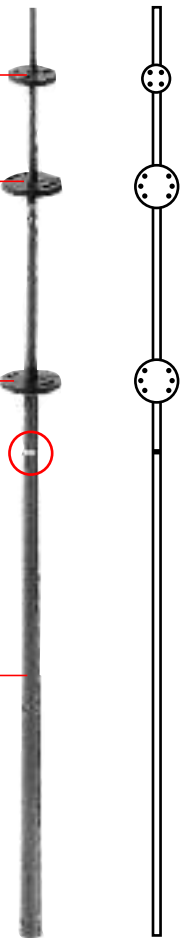

(B) 2 x

Sekundenkleber (FALLER EXPERT rapid 170500) verwenden.
 Use instant modelling cement (FALLER EXPERT rapid 170500).
 Utilisez la colle rapide (FALLER EXPERT rapid 170500).
 Gebruik secondenlijm (FALLER EXPERT rapid 170500).

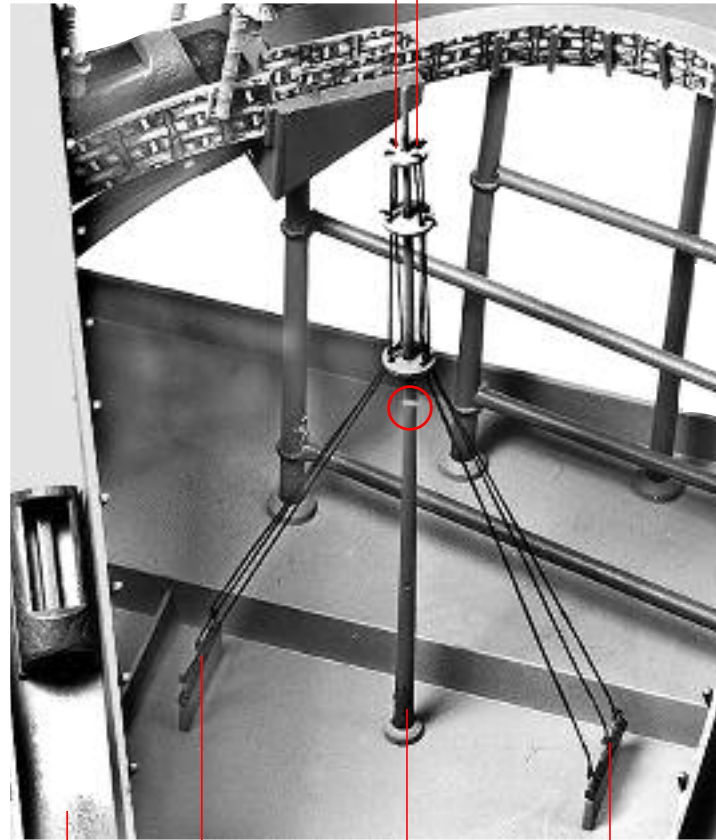

(C)

Z

A

B

A

Faden verknoten und den Knoten mit Sekundenkleber fixieren!
 Knot the thread and fix the thread with instand cement!
 Nouer le fil et renforcer le noeud avec une goutte de colle rapide!
 Draad vastknopen en de knoop met secondenlijm fixeren!

11/3

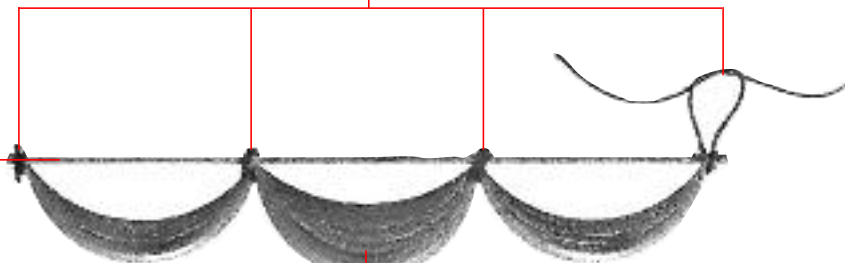

(D) 2 x

12/9

Faden verknoten und den Knoten mit Sekundenkleber fixieren!
 Knot the thread and fix the thread with instand cement!
 Nouer le fil et renforcer le noeud avec une goutte de colle rapide!
 Draad vastknopen en de knoop met secondenlijm fixeren!

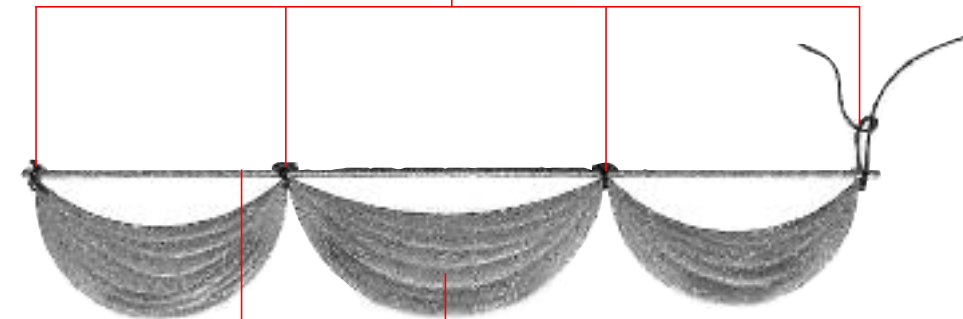

(E) 2 x

11/2

12/10

(D)

(E)

(C)

(F)

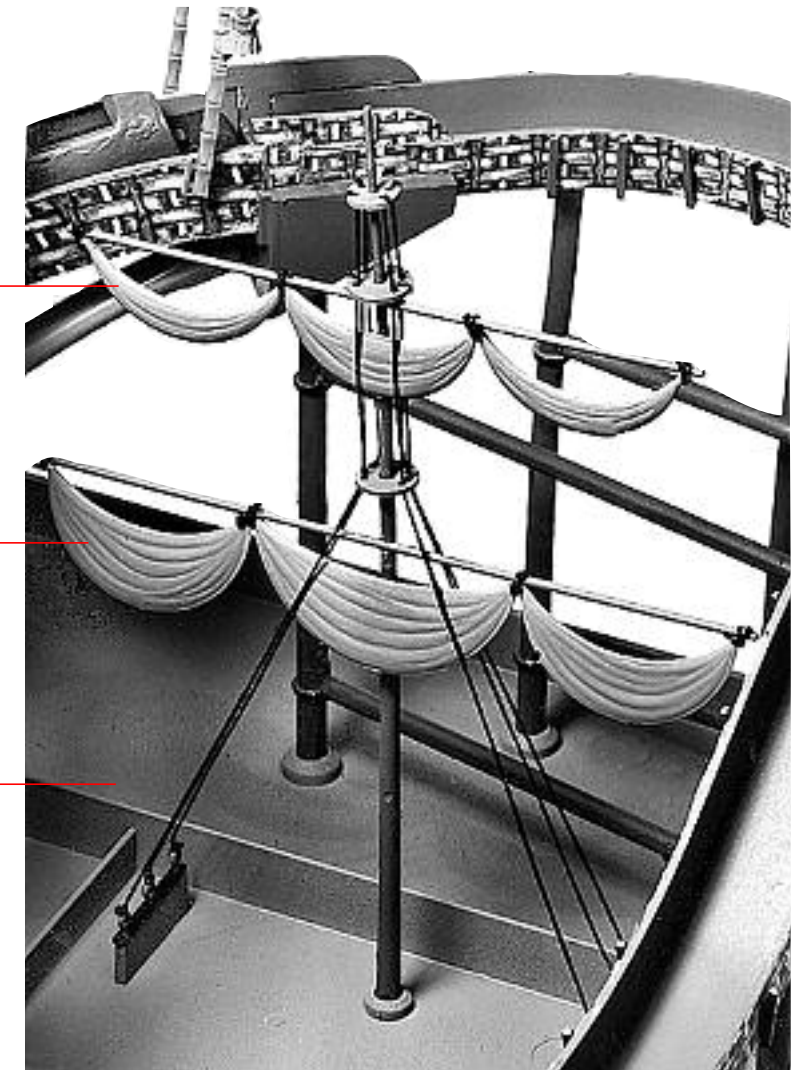

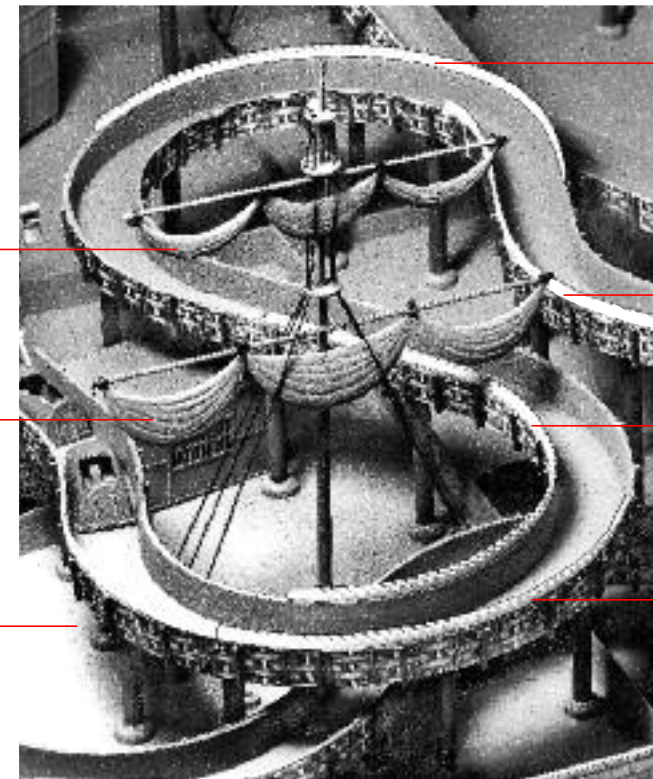
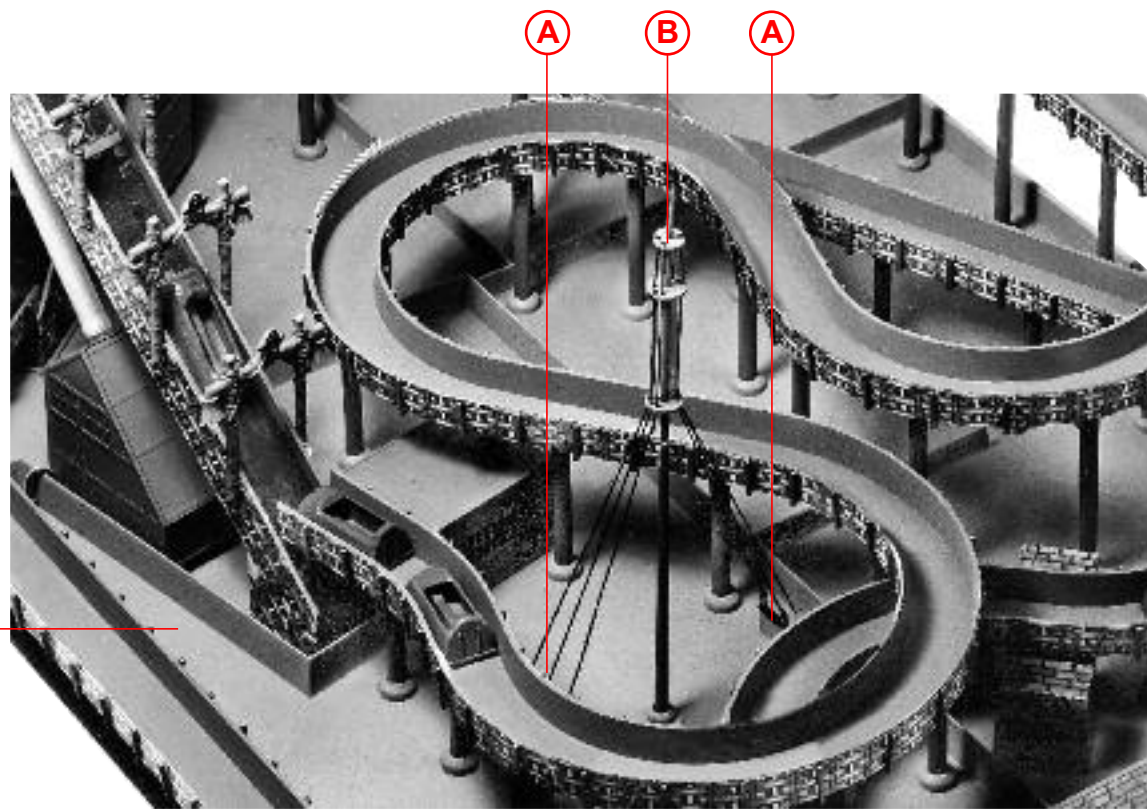

Sekundenkleber verwenden.
Use instant modelling cement.
Utilisez la colle rapide.
Gebruik seconden - lijm.

5/17

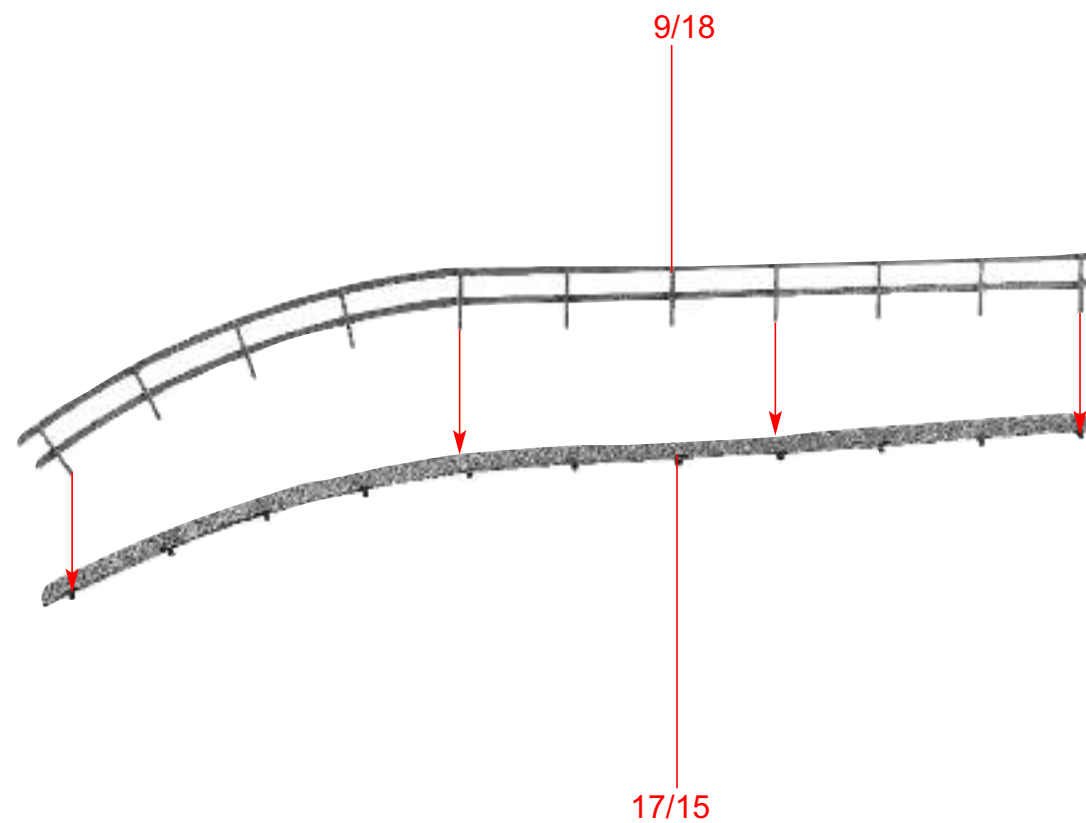

F

G

A

B

A

D

E

G

H

I

H

J

9/18

17/15

16

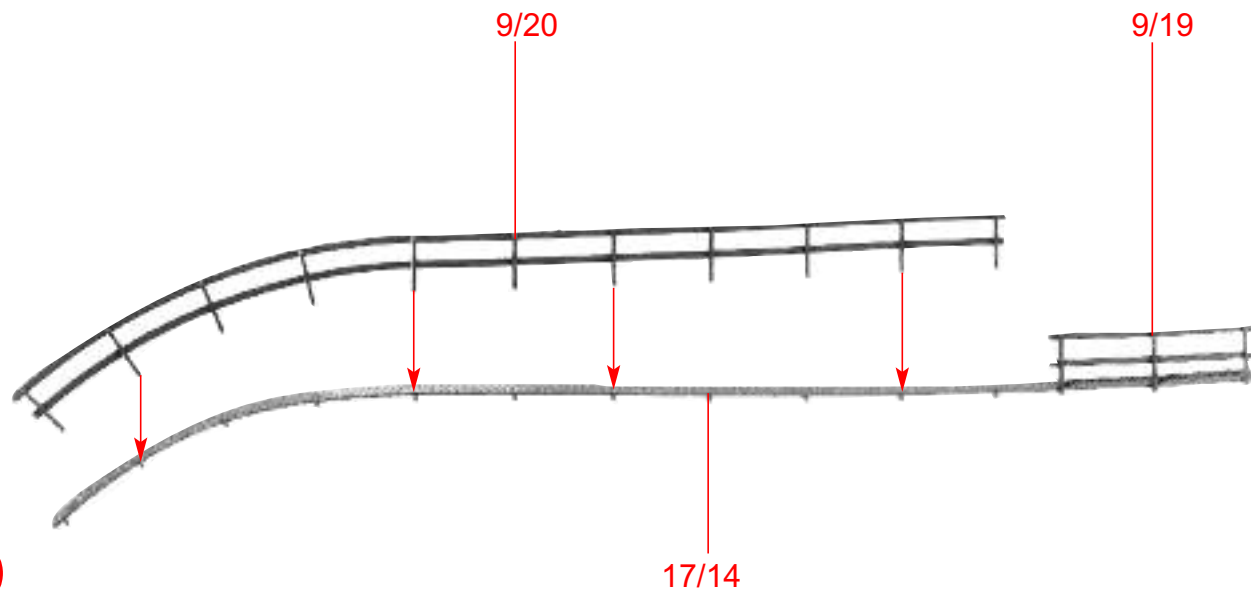

K

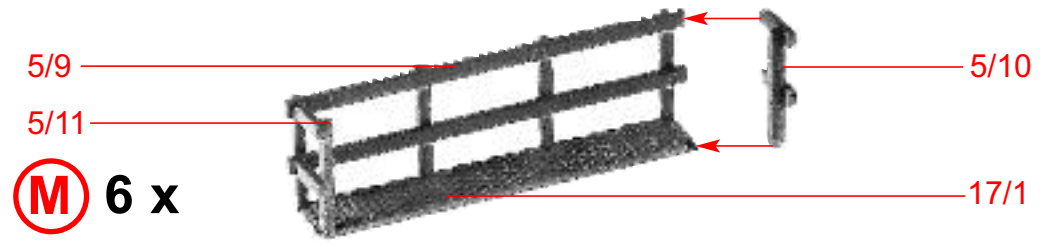

M 6 x

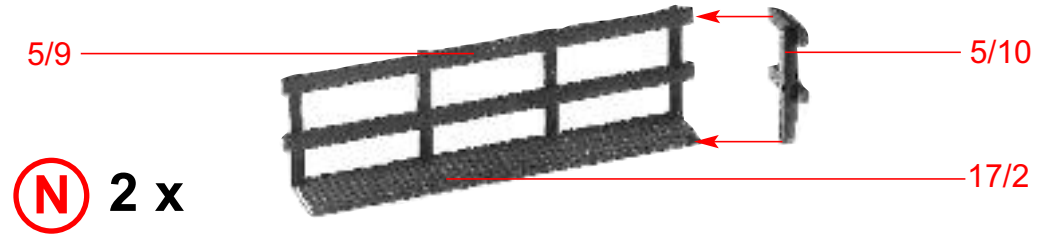

N 2 x

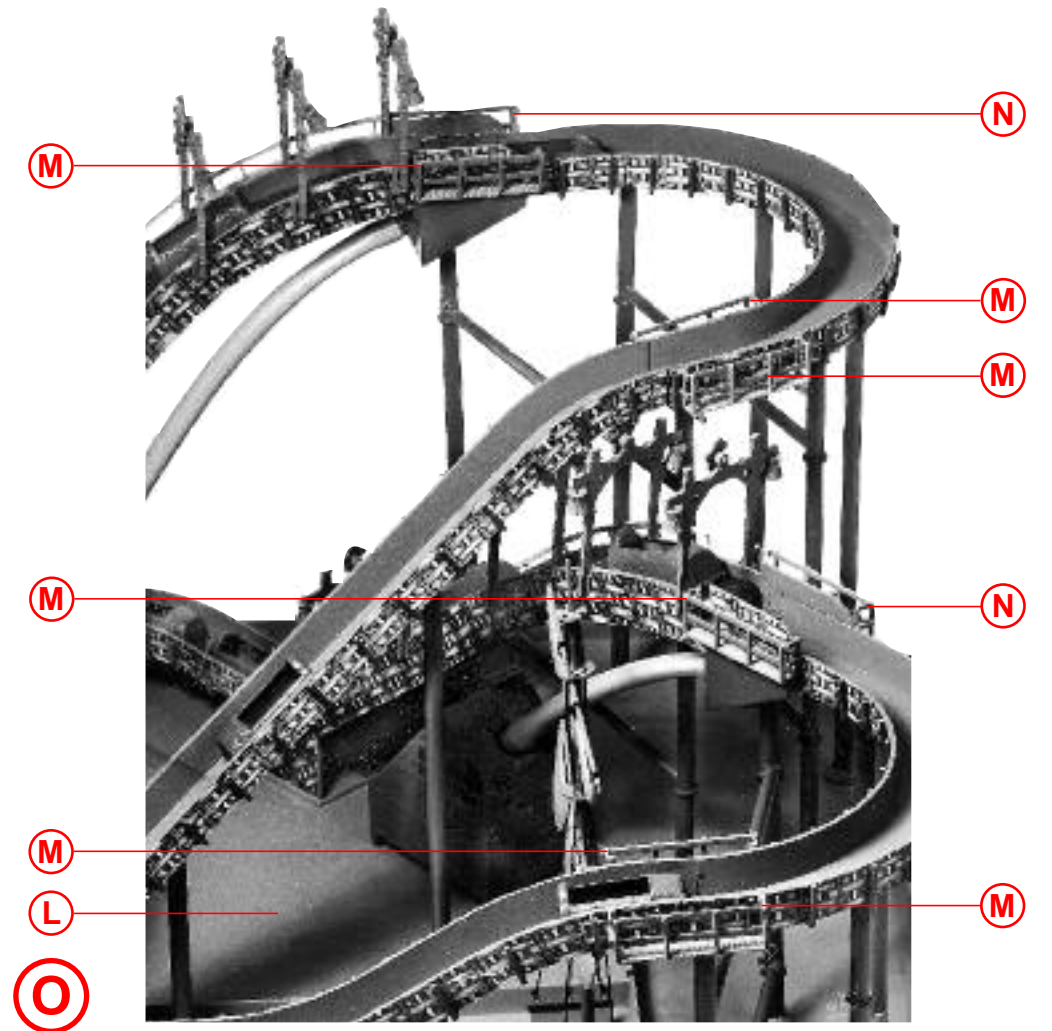
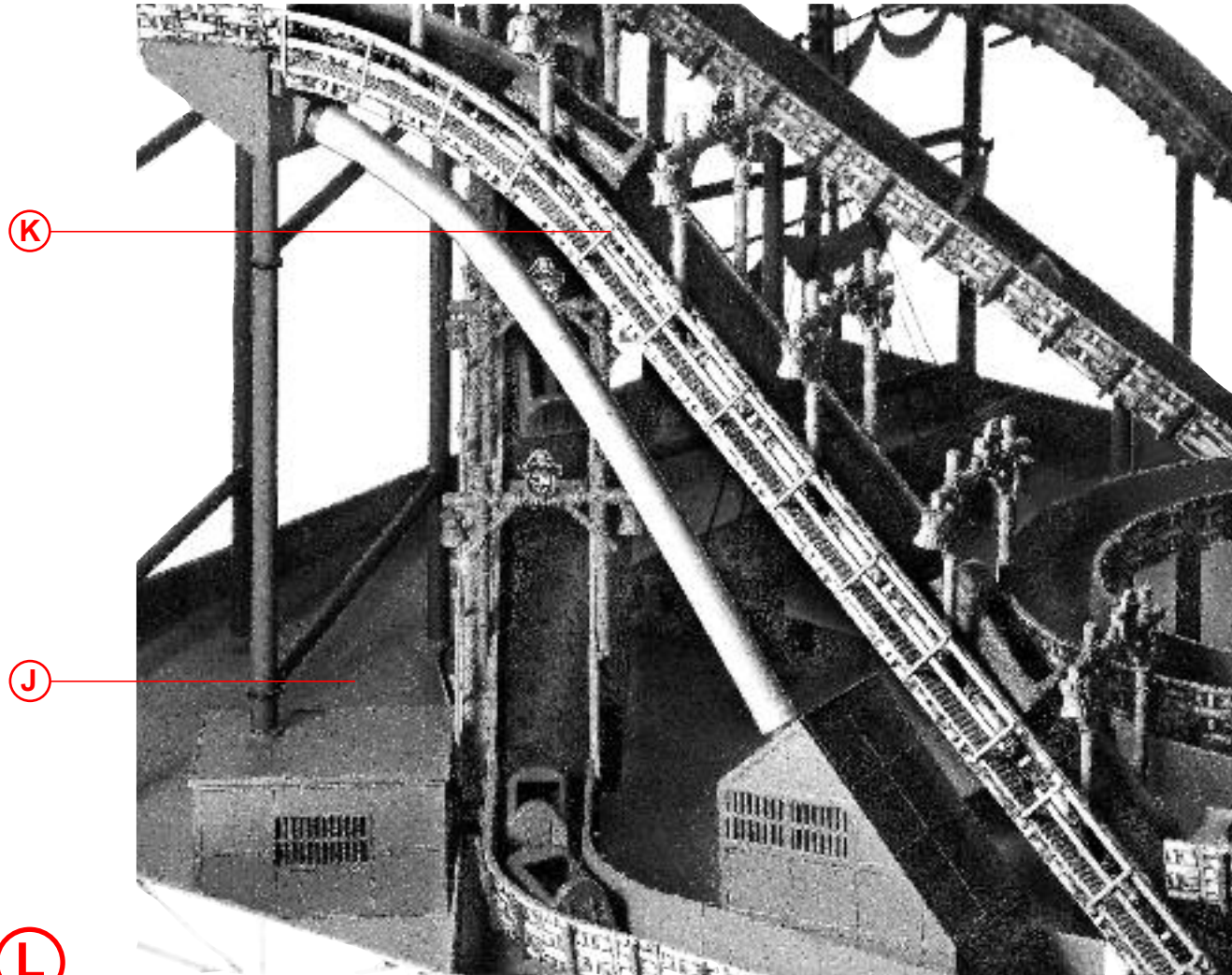

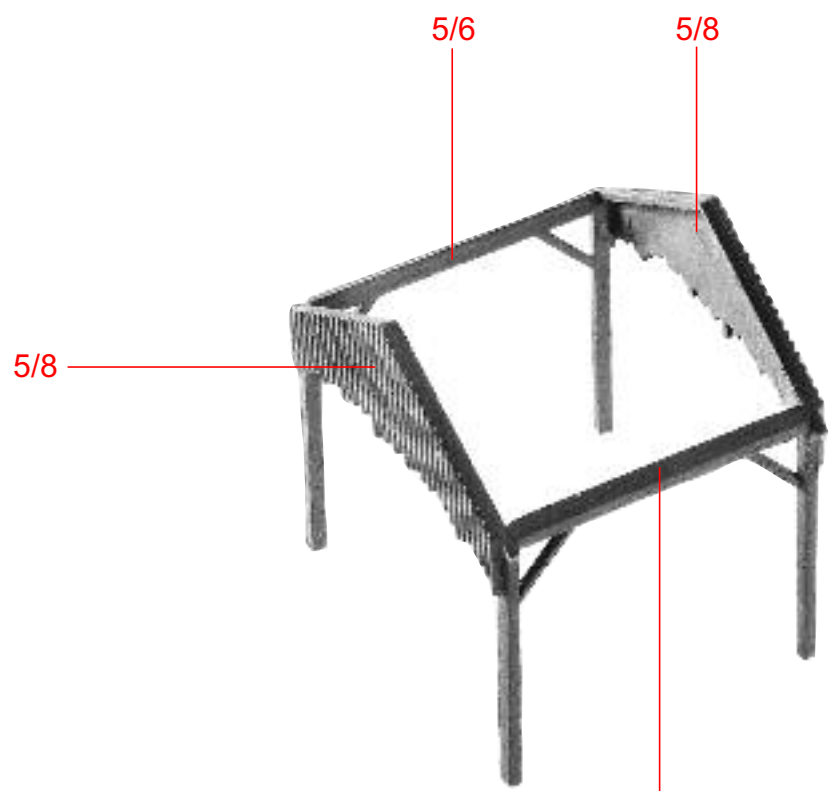

P 2 x

5/6

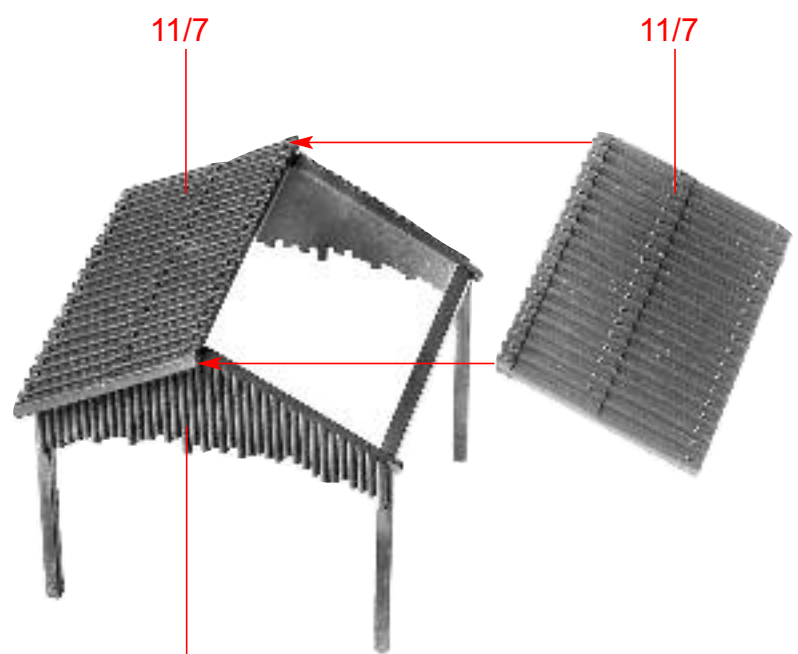

Q 2 x

P

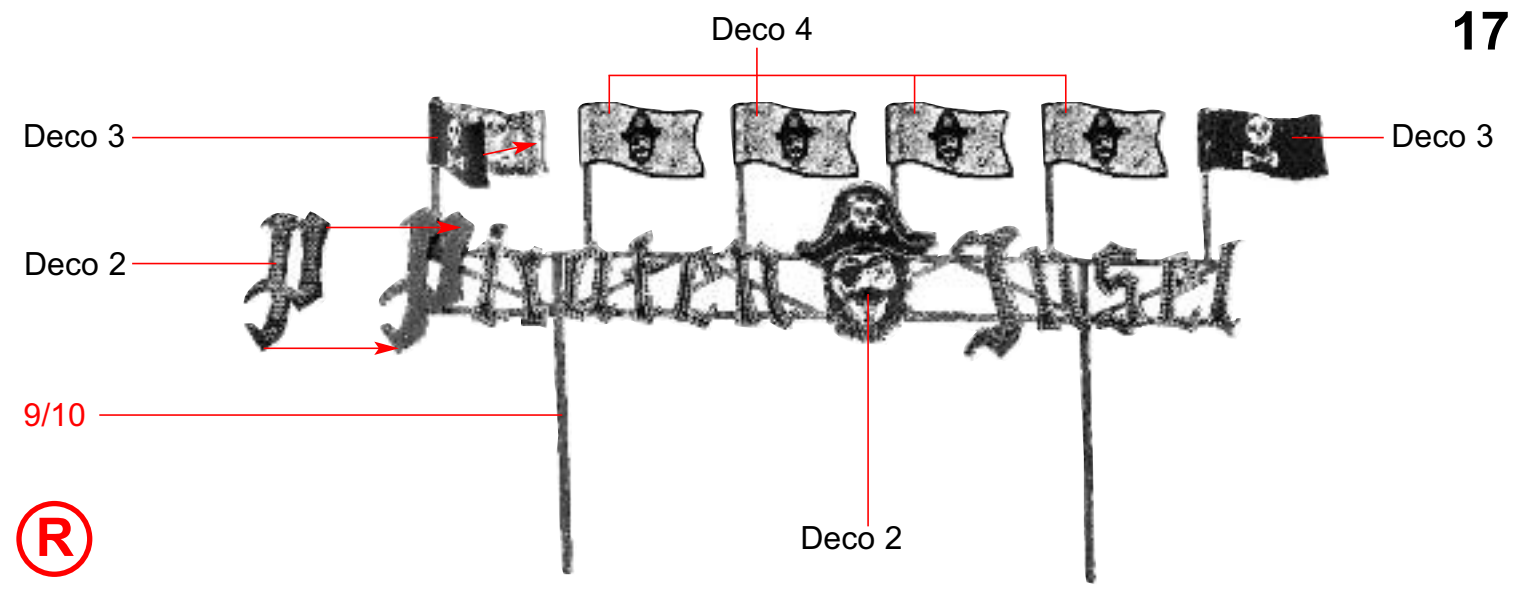

R

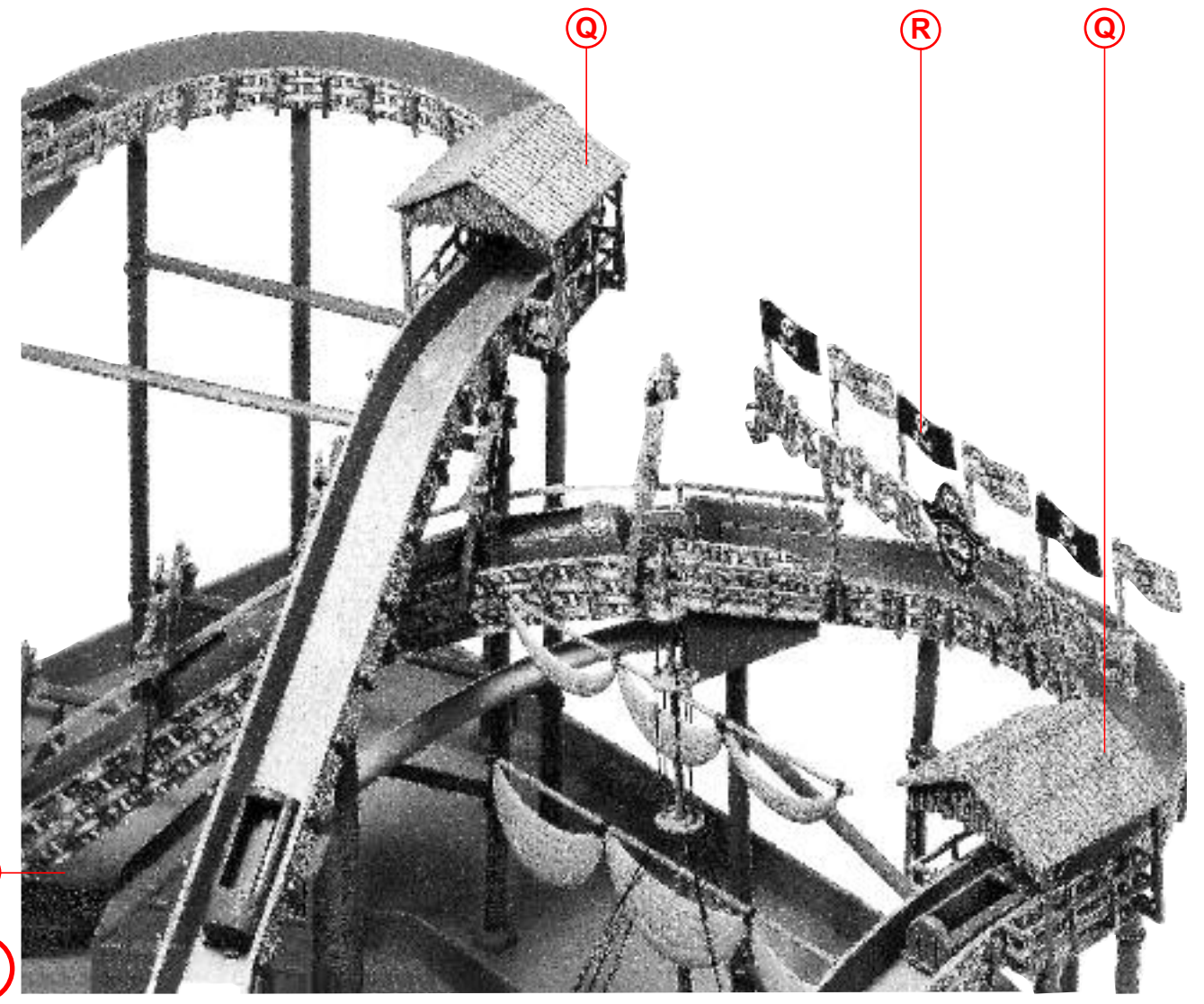

S

S

18

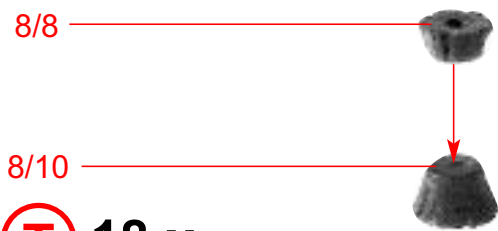

T 18 x

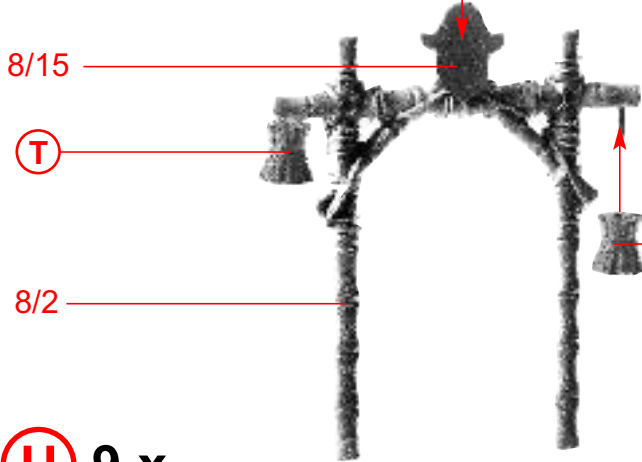

U 9 x

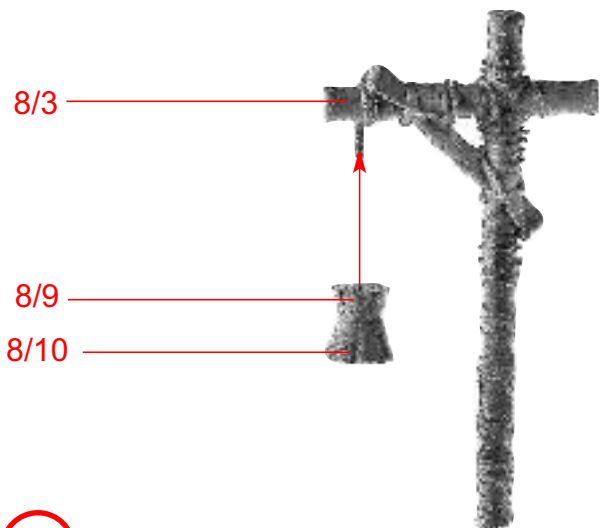

V 18 x

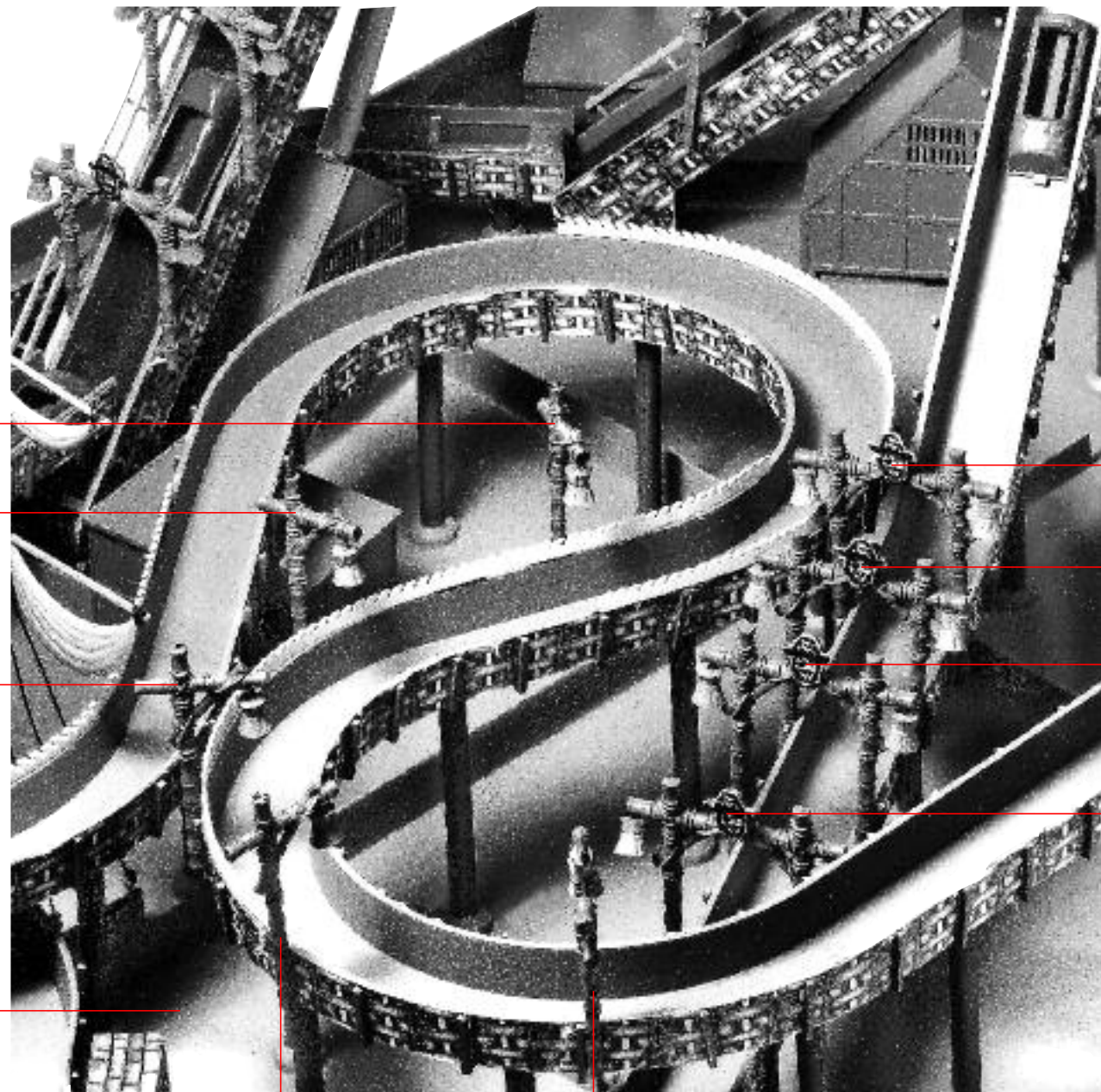

V

U

S

W

V

V

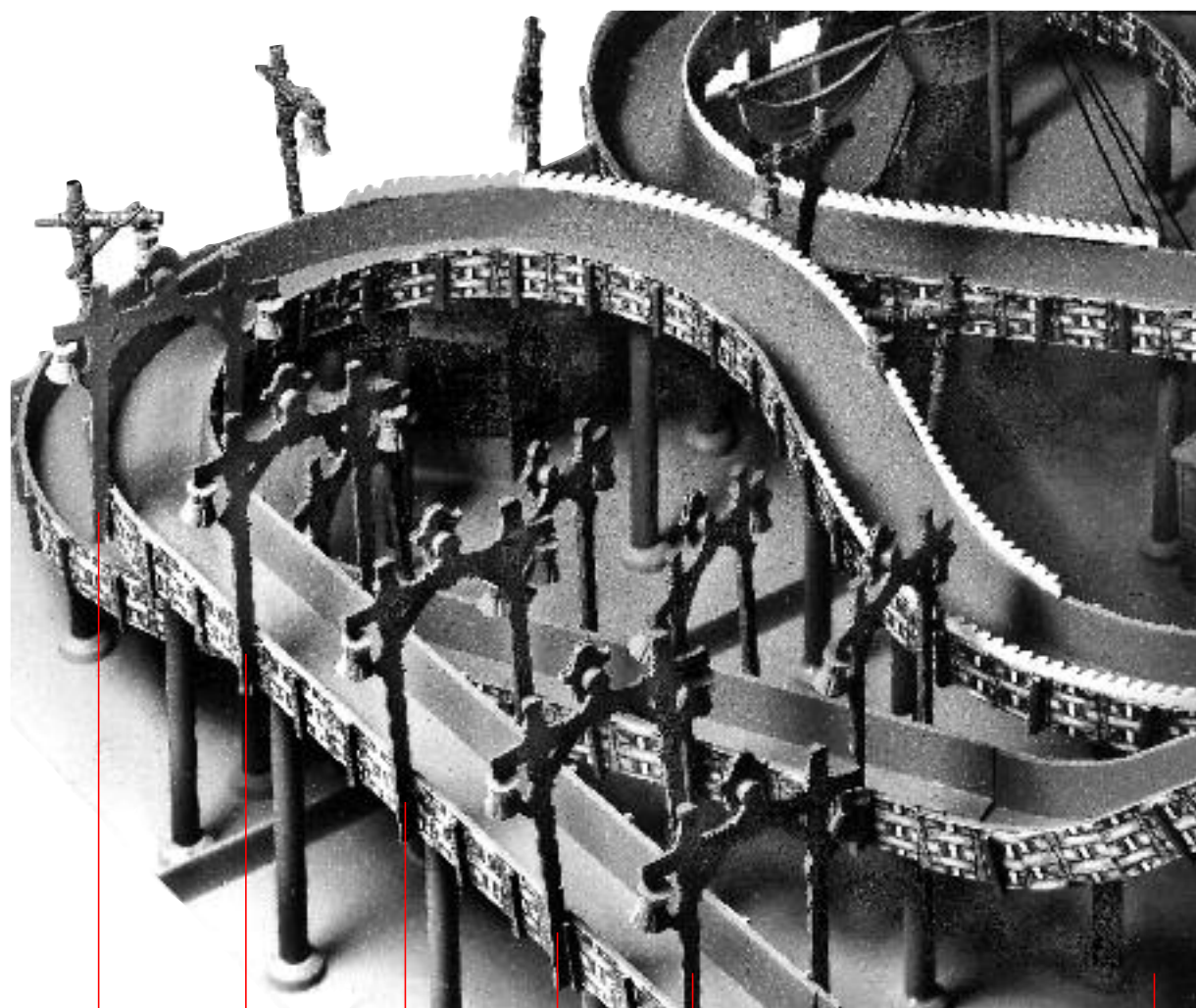

X

U

W

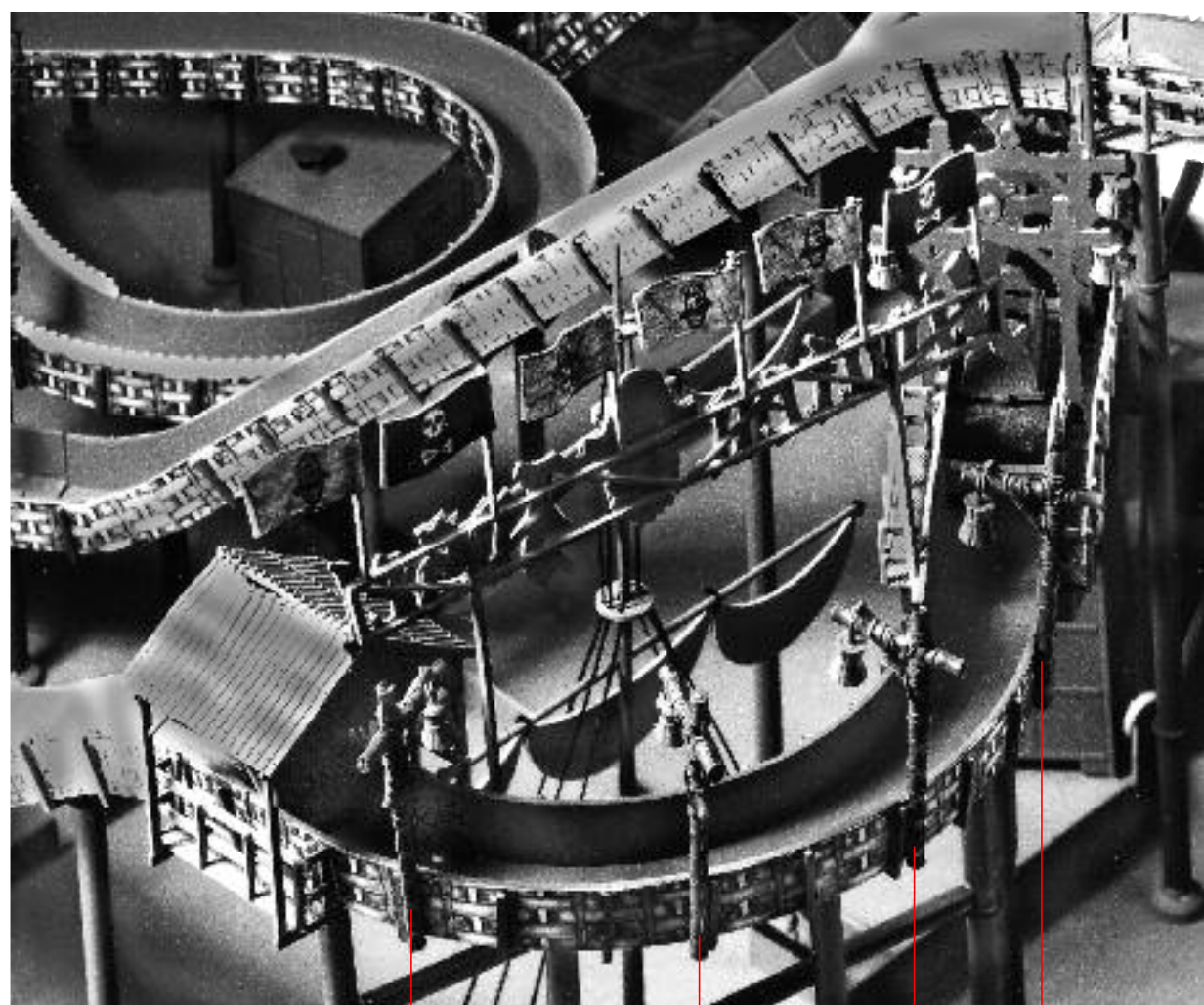

V

V

V

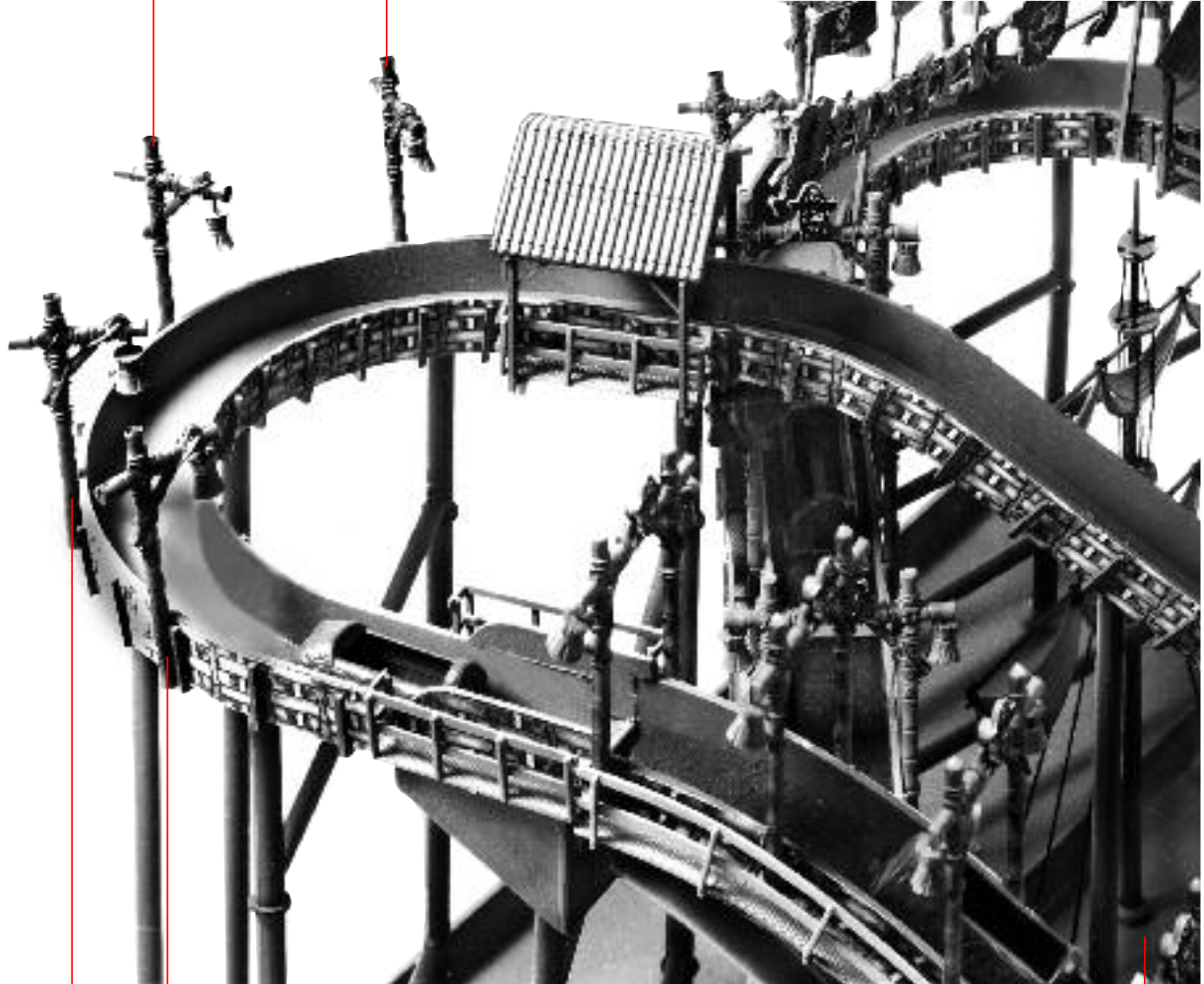

V

V

Y

X

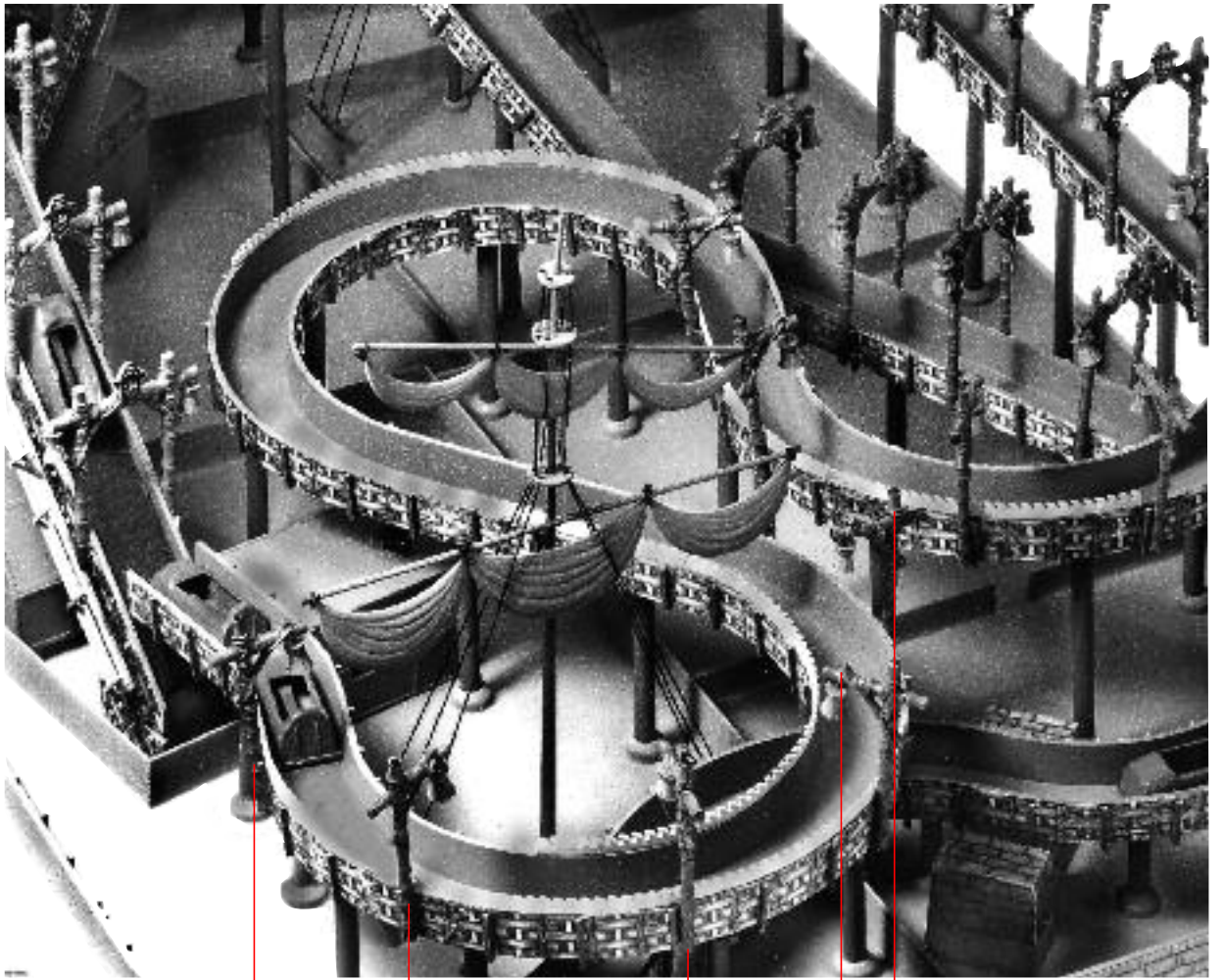

V

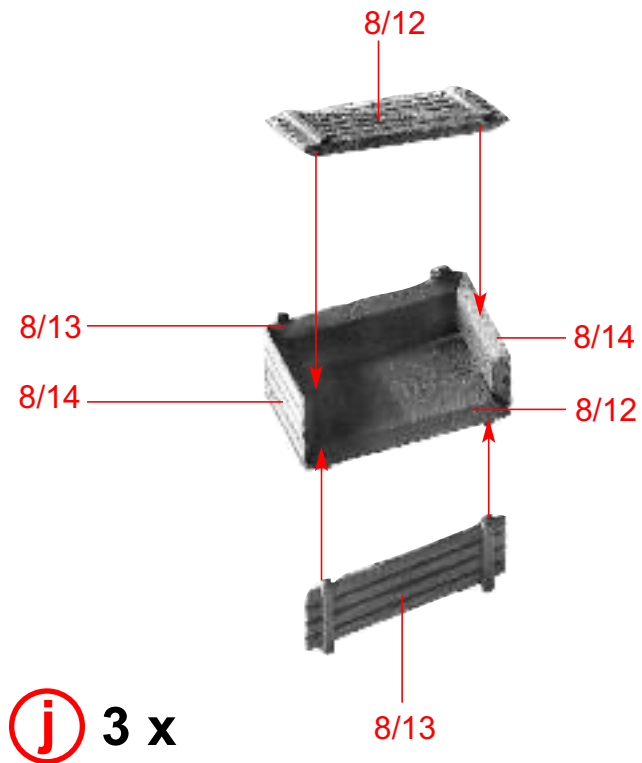
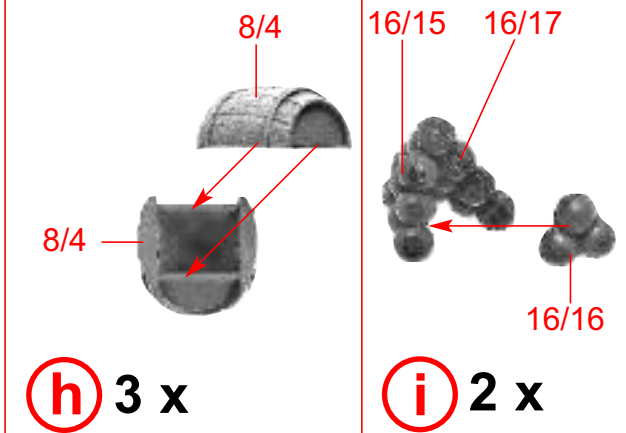
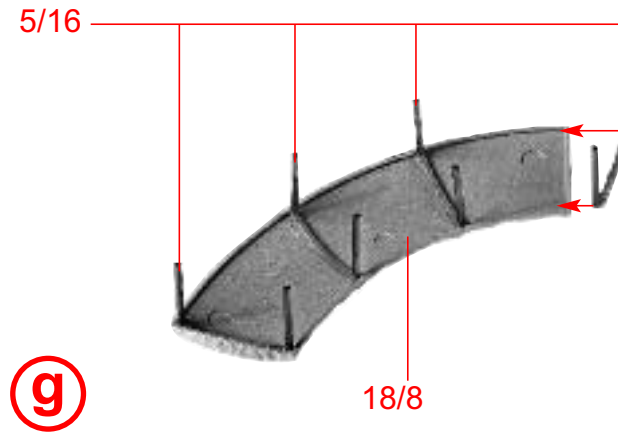
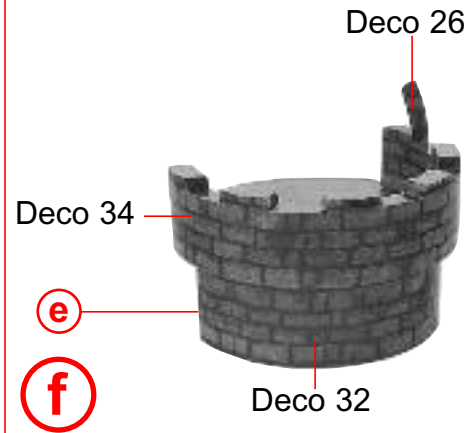
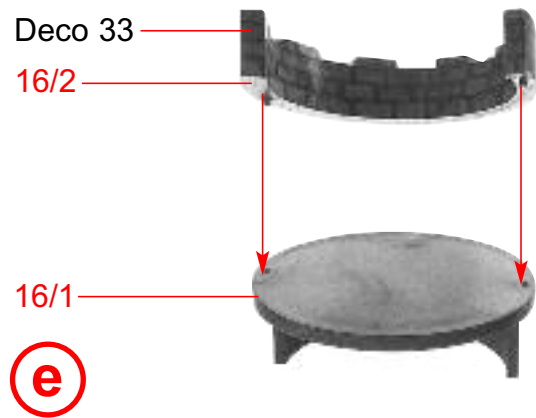
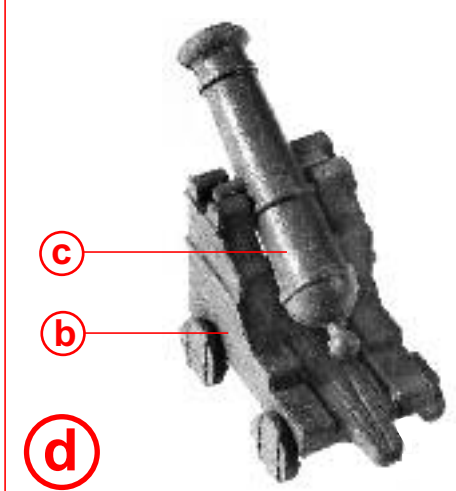
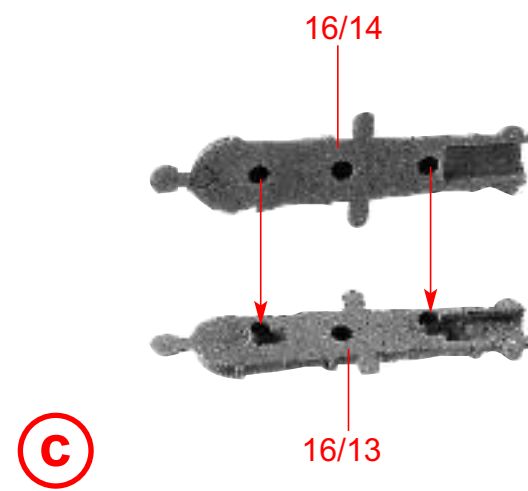
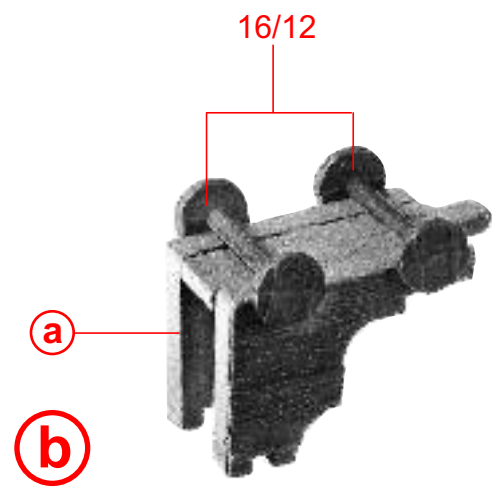
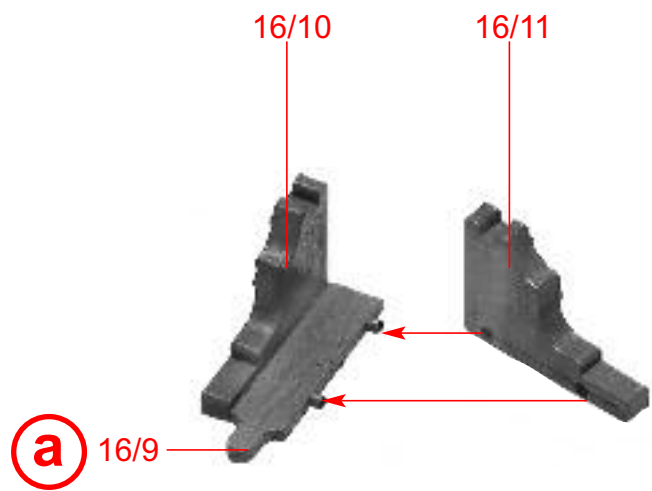

Inhalt	Tüte	Contents	bag
Contenu	sachet	Inhoud	zakje

17/16

17/17

Sekundenkleber (FALLER EXPERT rapid 170500) verwenden.
Use instant modelling cement (FALLER EXPERT rapid 170500).
Utilisez la colle rapide (FALLER EXPERT rapid 170500).
Gebruik secondenlijm (FALLER EXPERT rapid 170500).

Inhalt	Tüte	Contents	bag
Contenu	sachet	Inhoud	zakje

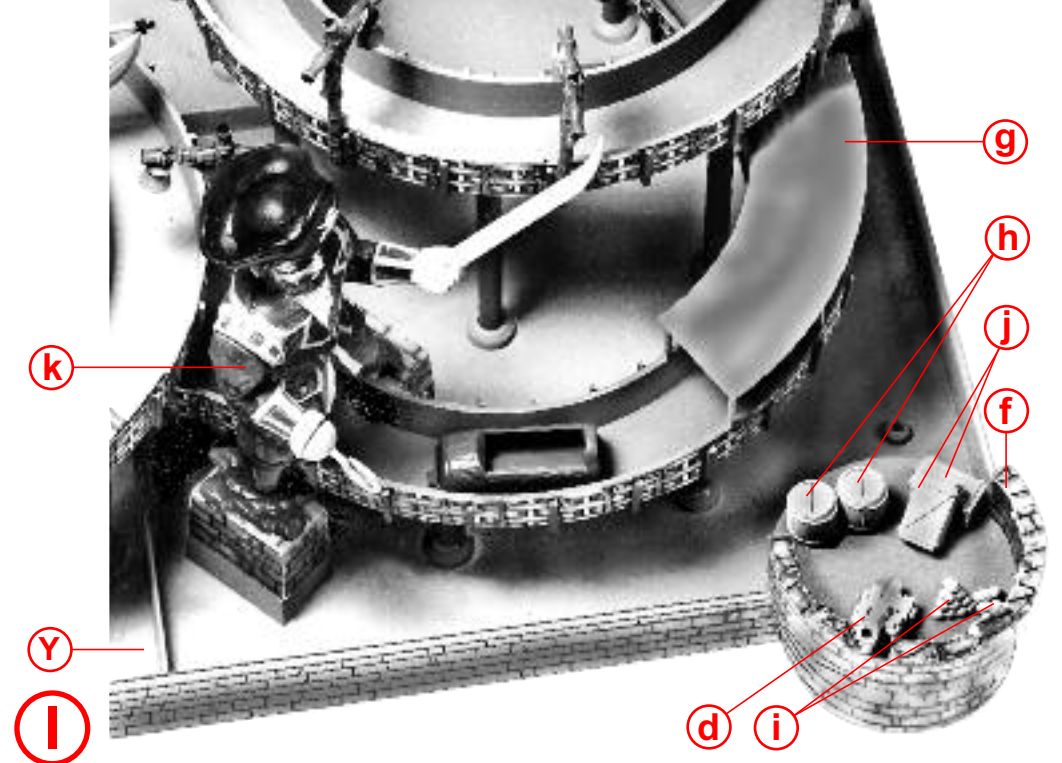

22

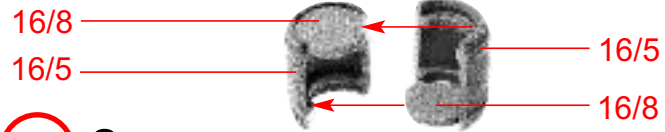

m 2 x

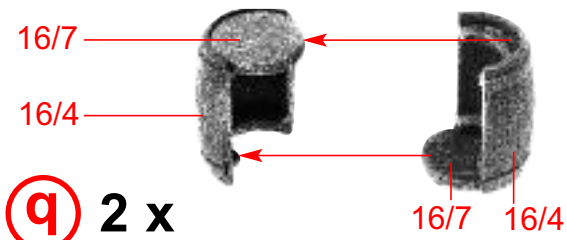

q 2 x

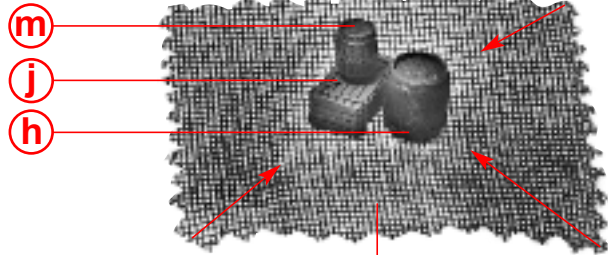

m
j
h

n
Inhalt Tüte Contents bag
Contenu sachet Inhoud zakje

Faden
Cord
Aiguillée
Garen

n

o

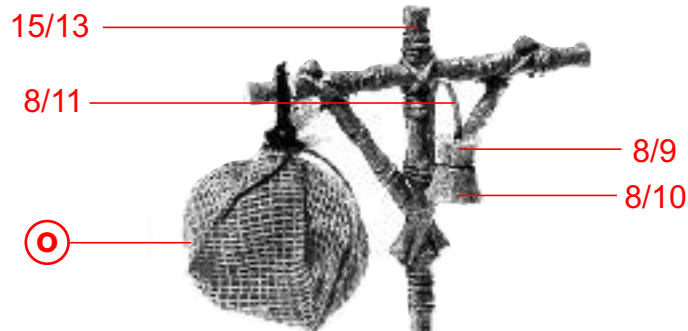

o

p

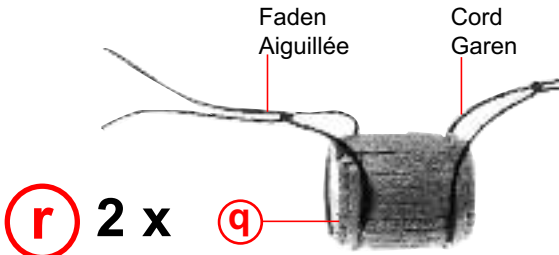

r 2 x **q**

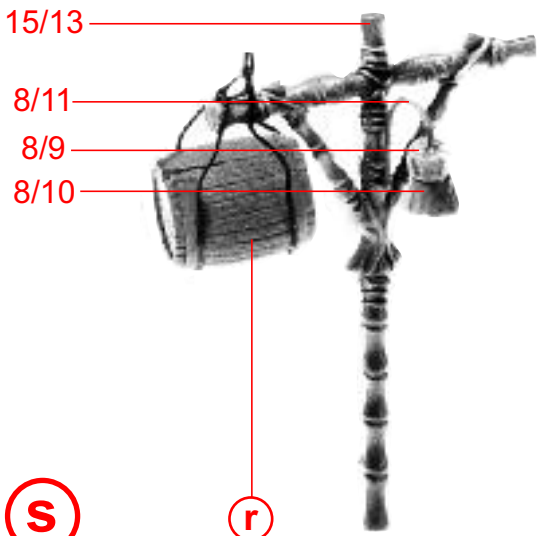

s

r

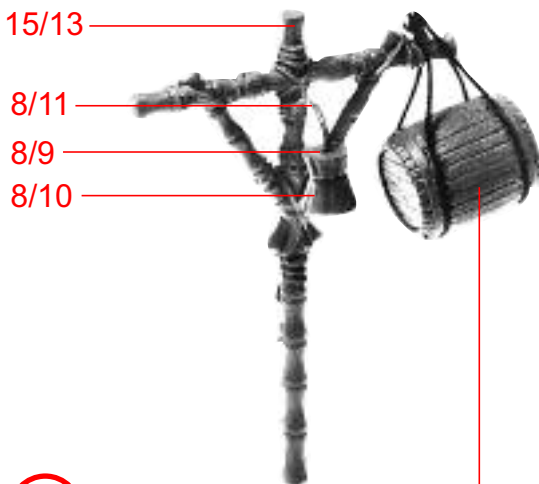

t

r

u

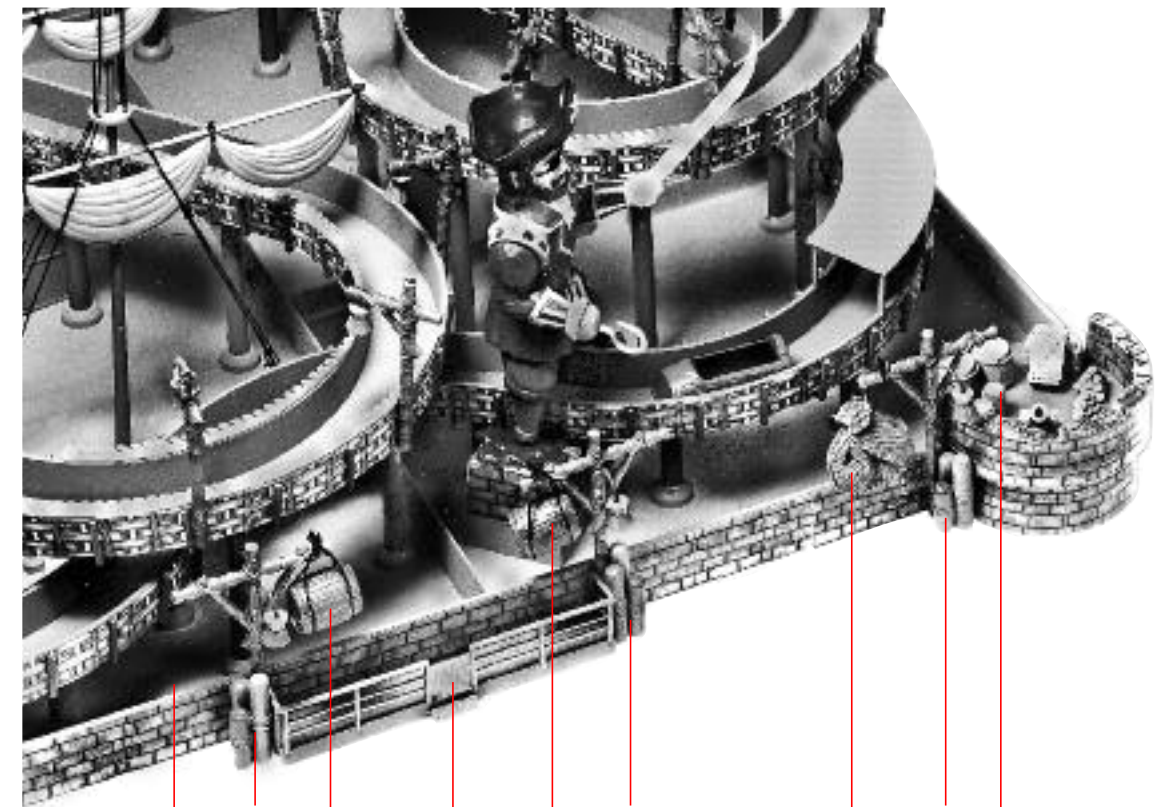

v

l

8/5
8/6
8/7

t

u

8/5
8/6
8/7

s

p

8/5
8/6
8/7

m

5/14

5/12

5/13

5/15

17/3

Art.-Nr. 180671 liegt nicht bei
not included
non jointe
niet bijgevoegd

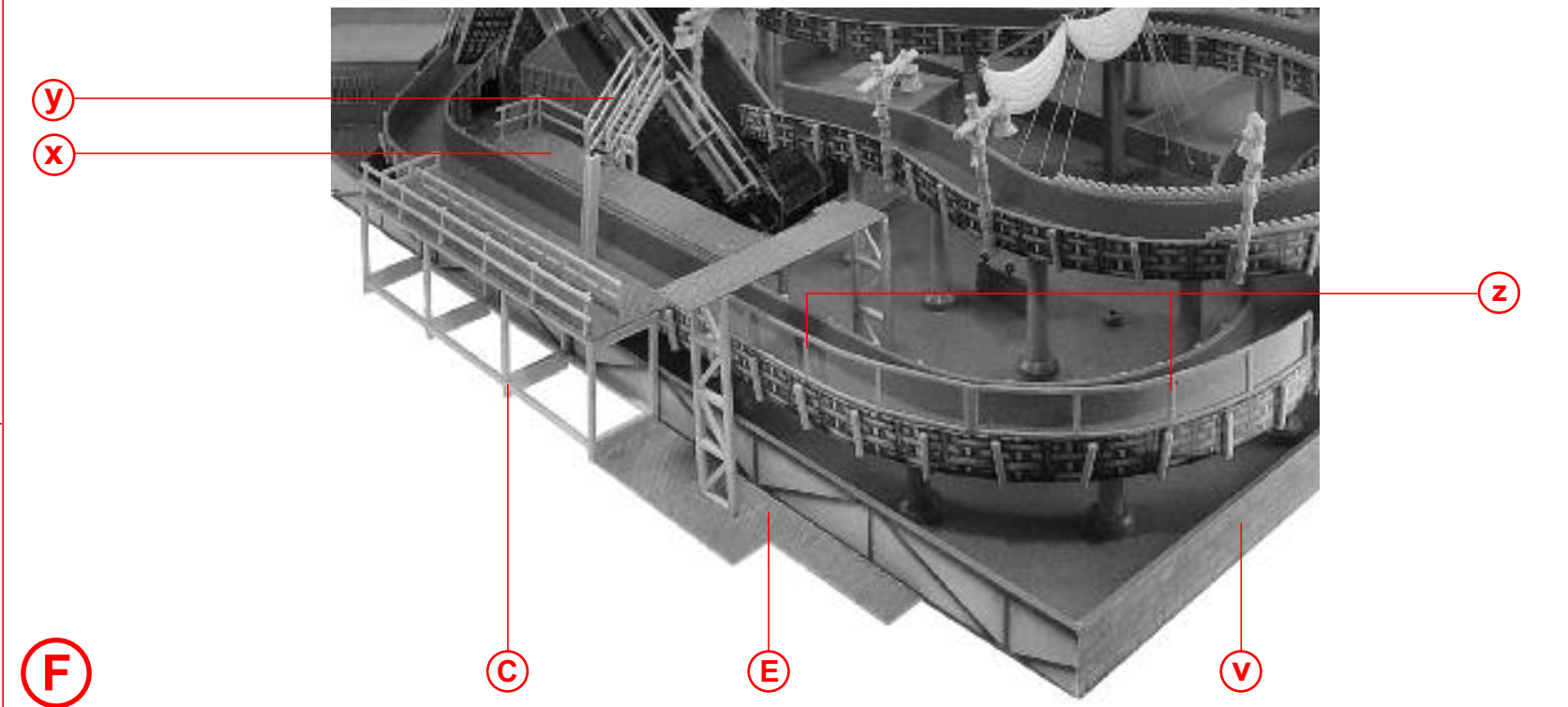
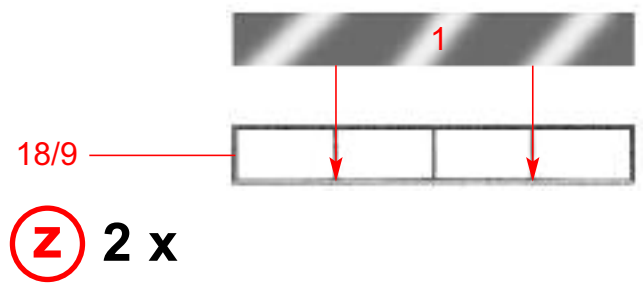
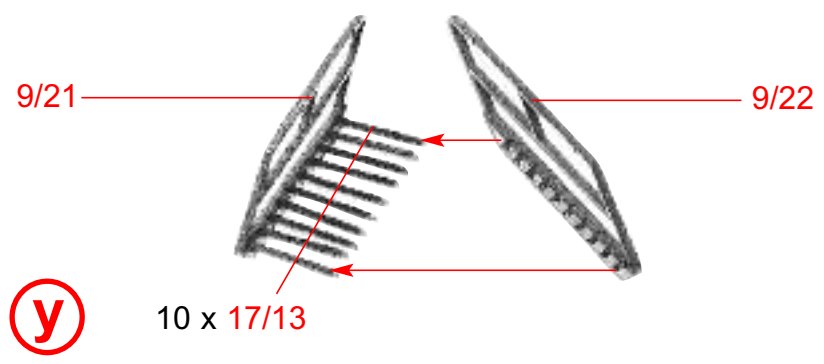
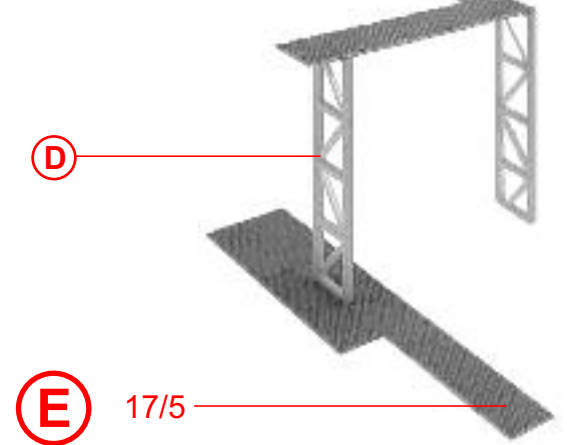
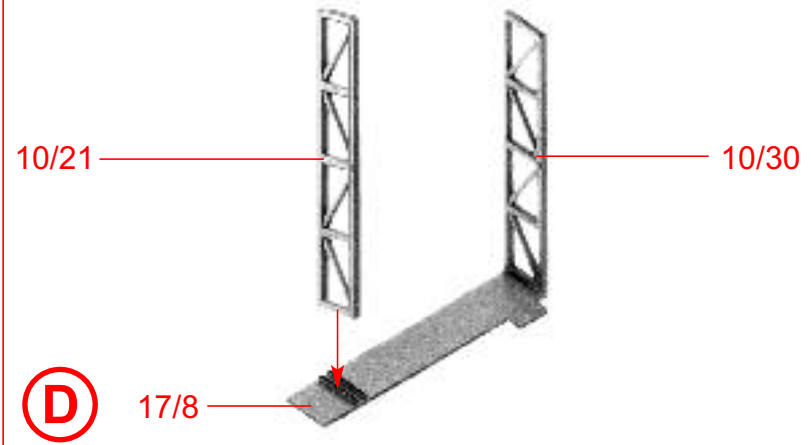
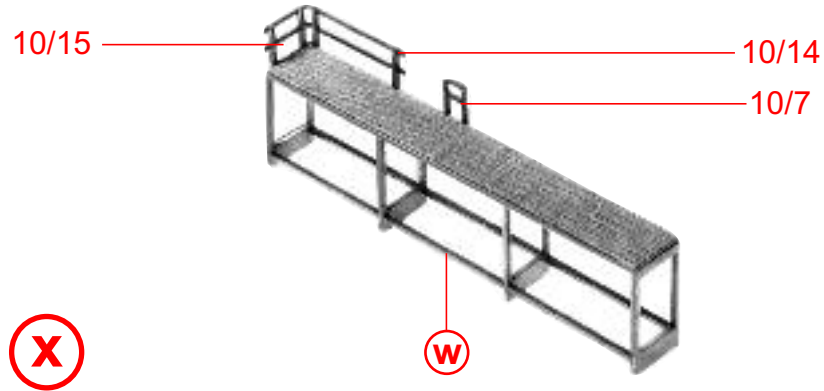
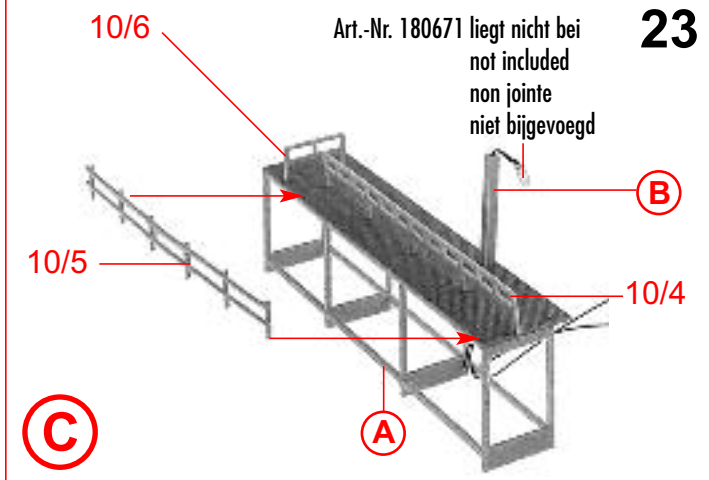
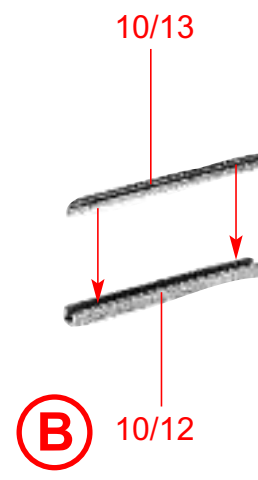
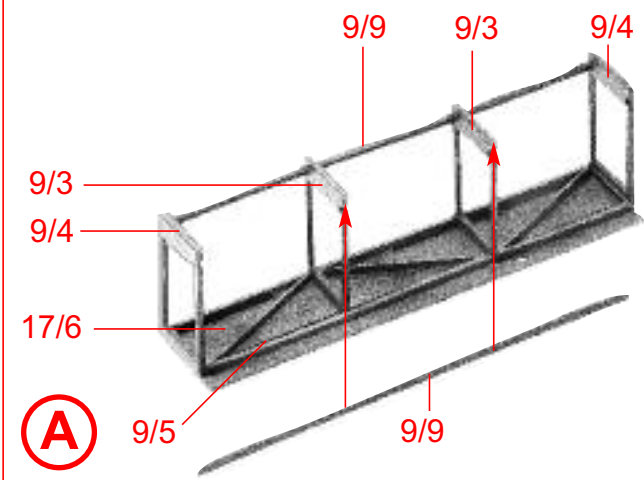
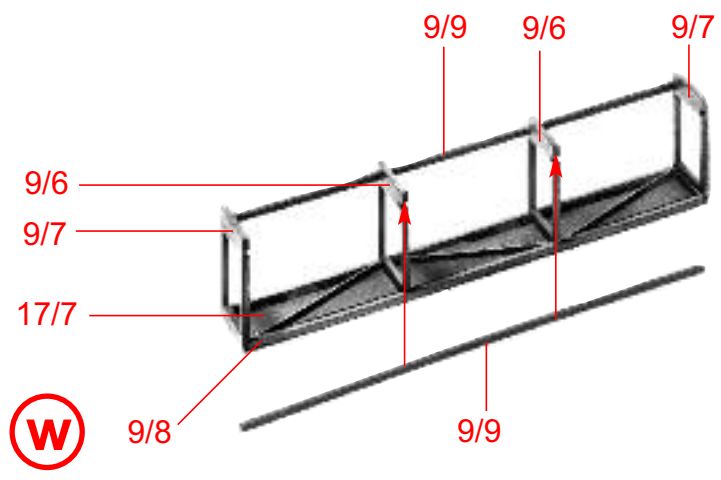

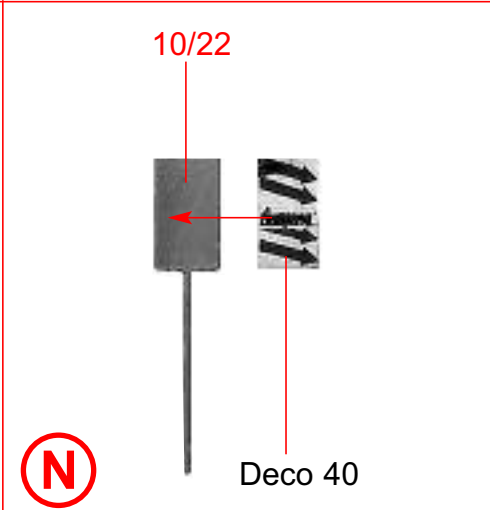
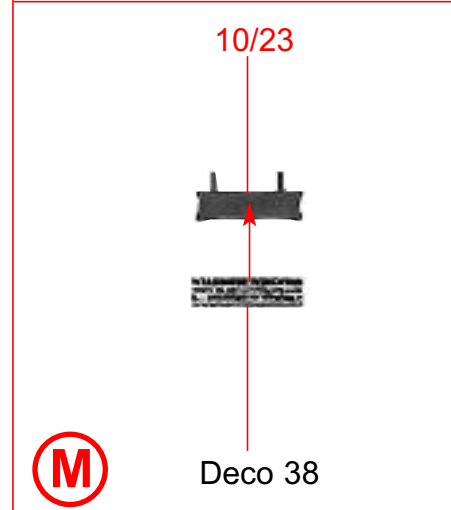
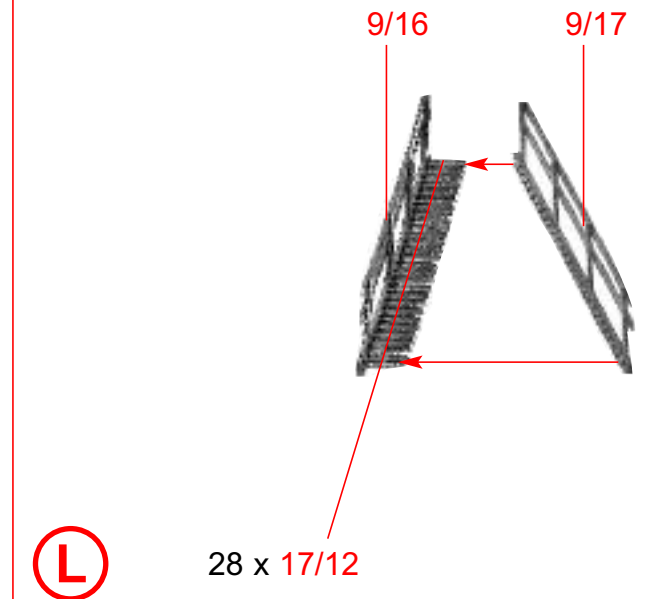
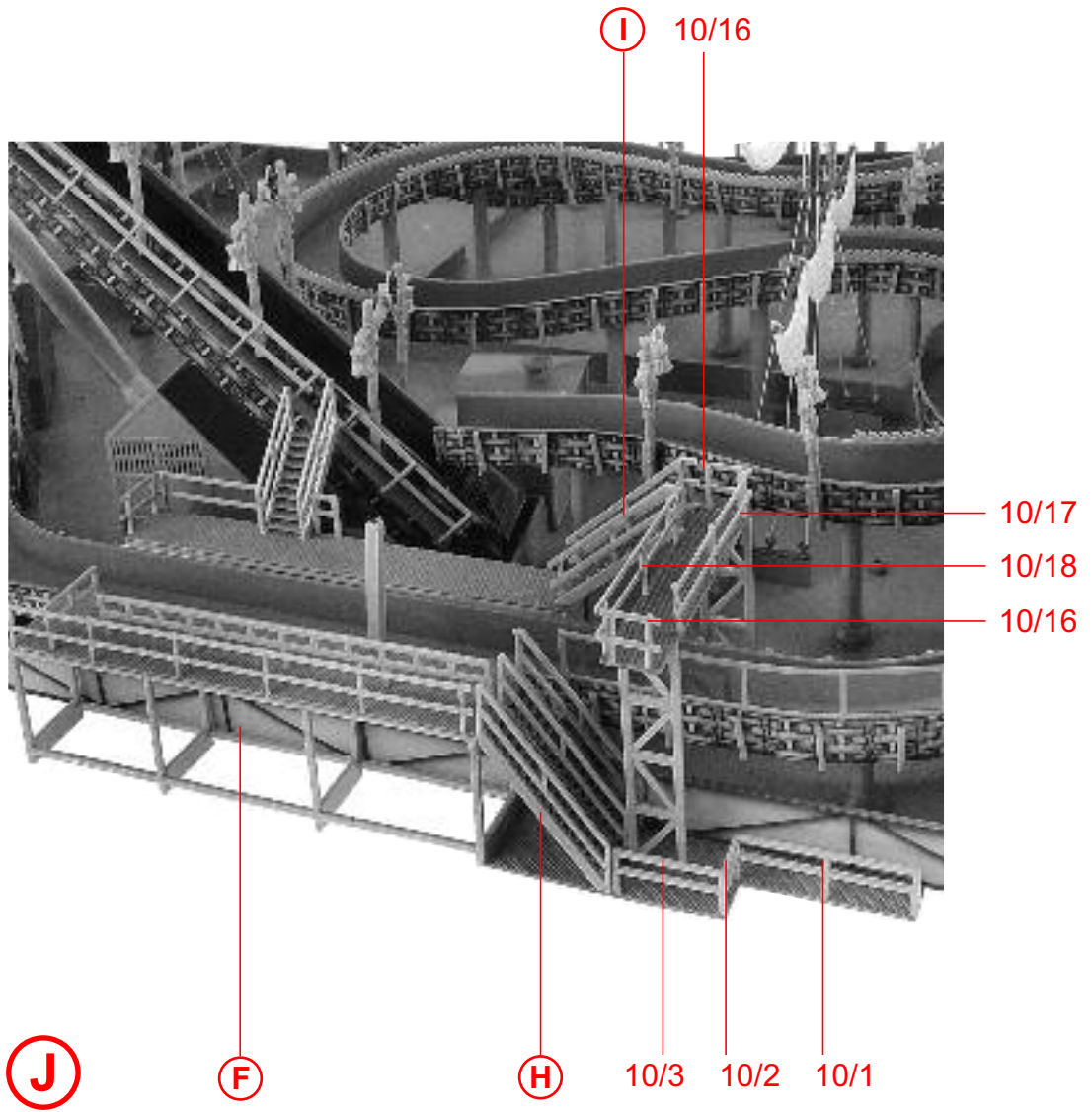
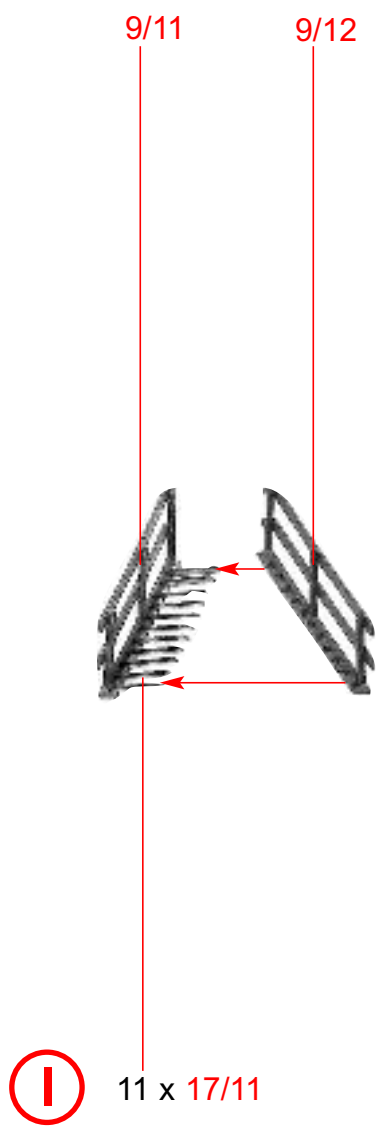
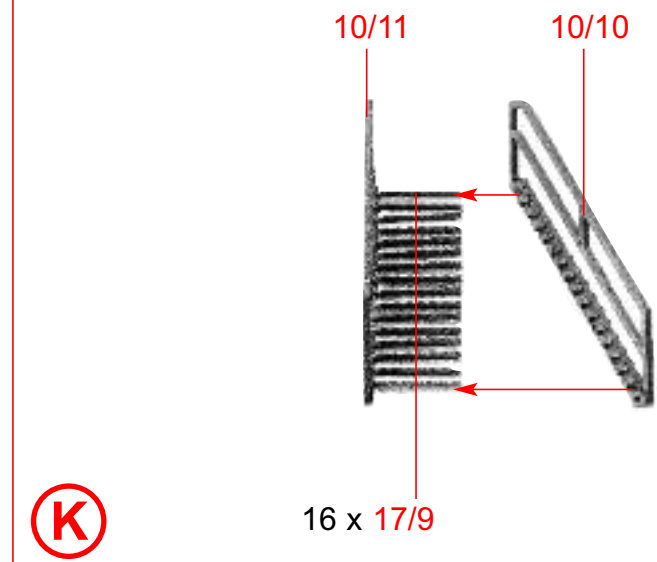
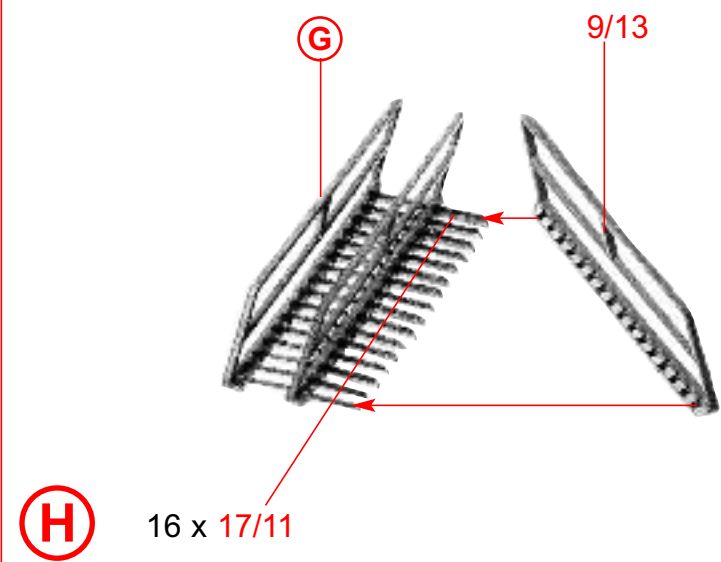
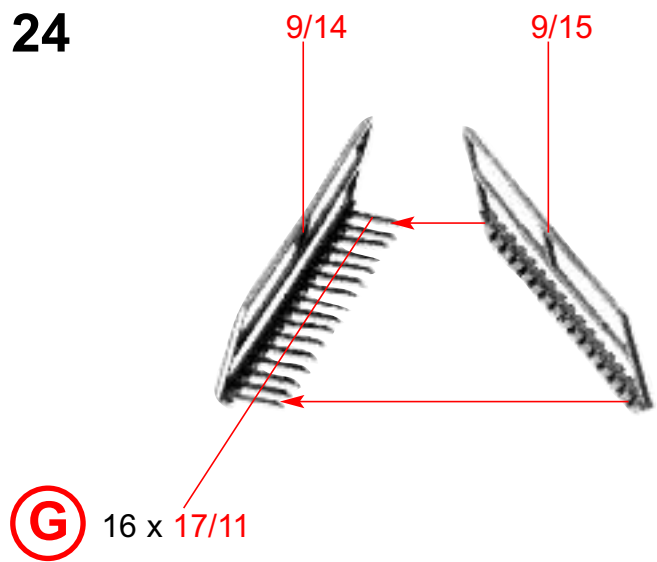

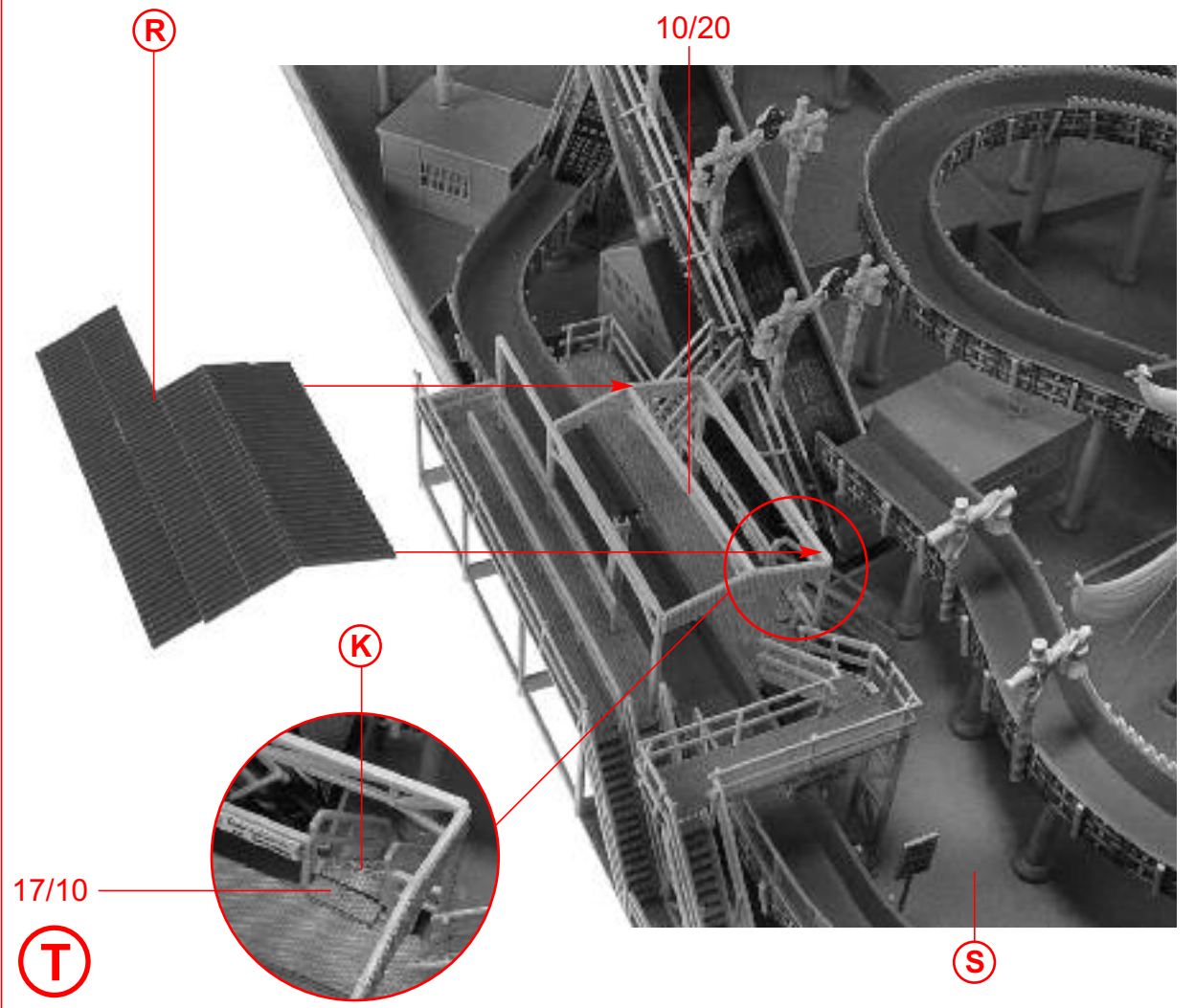
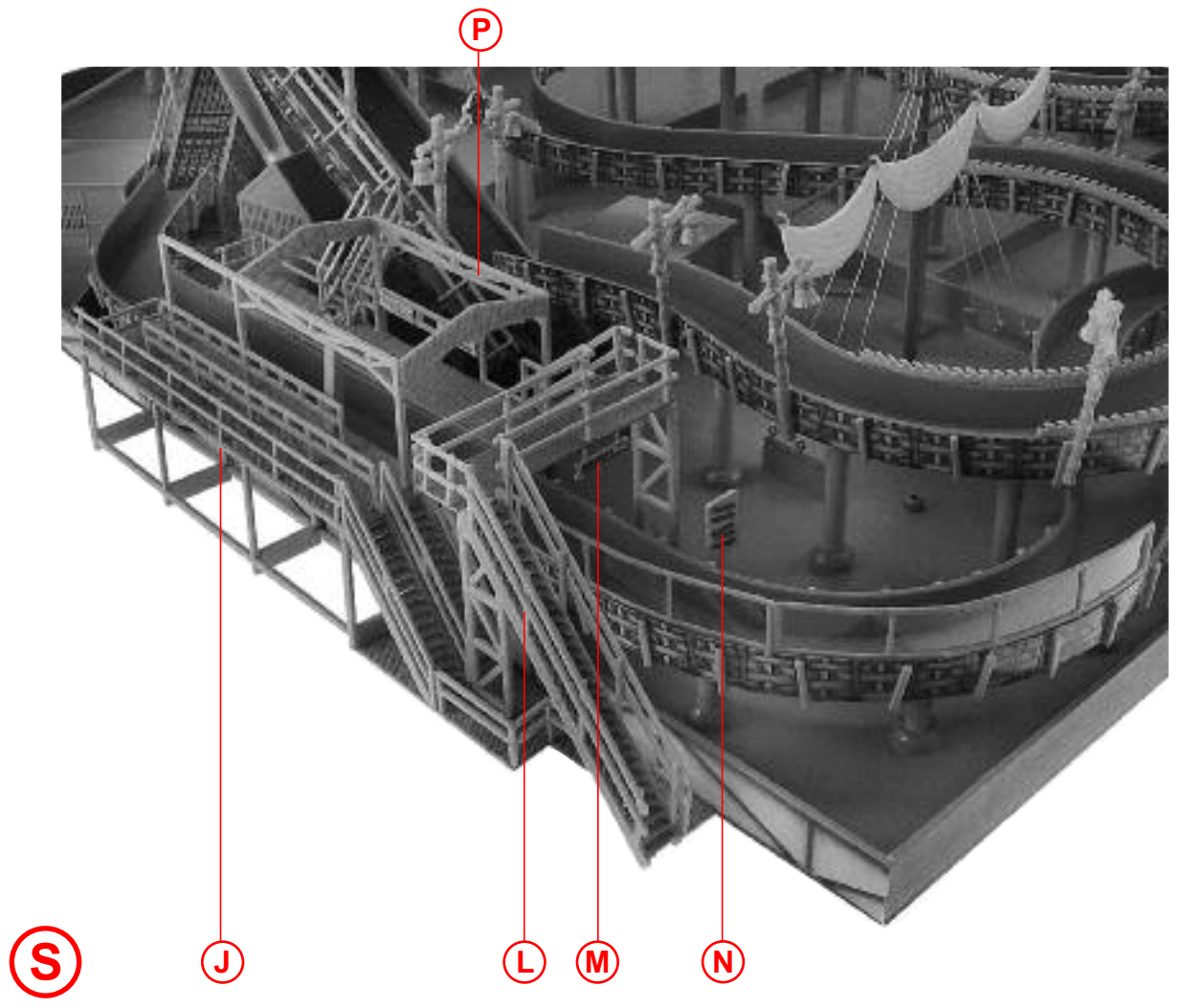
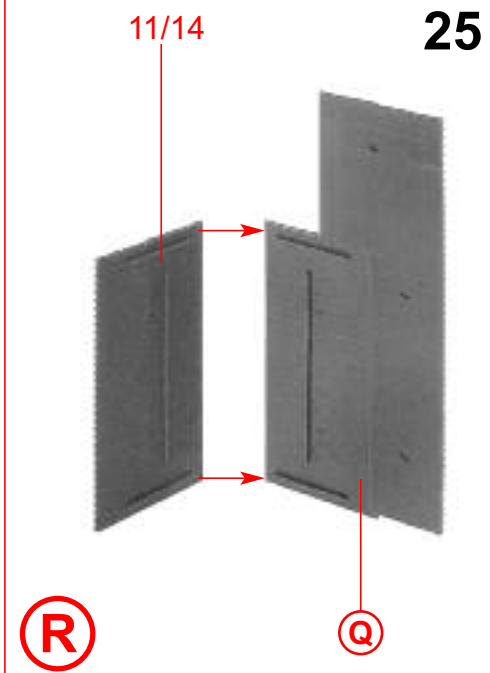
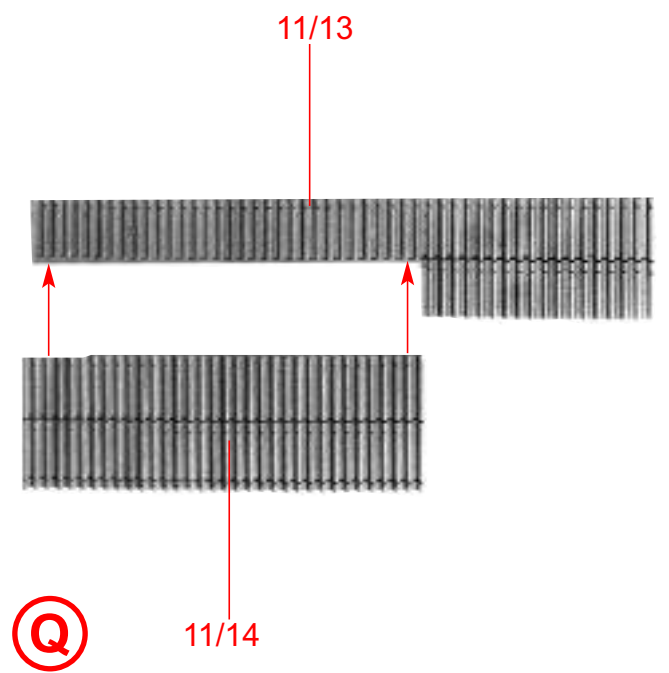
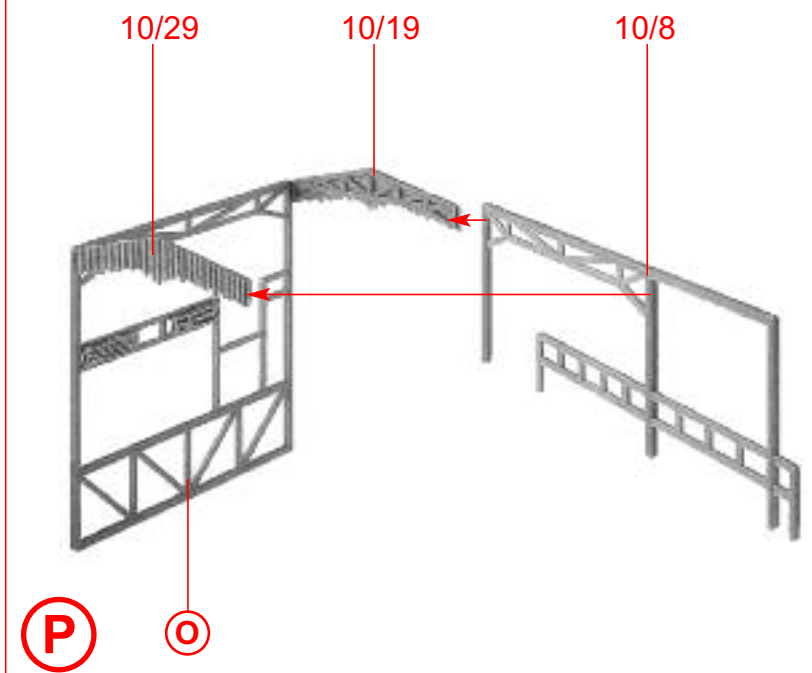
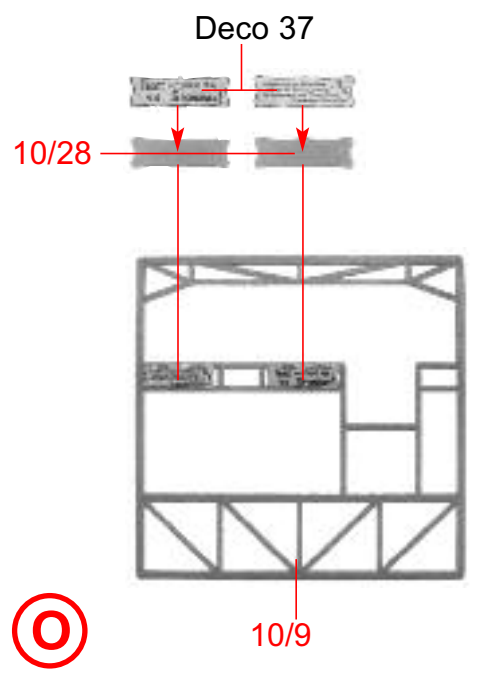

26

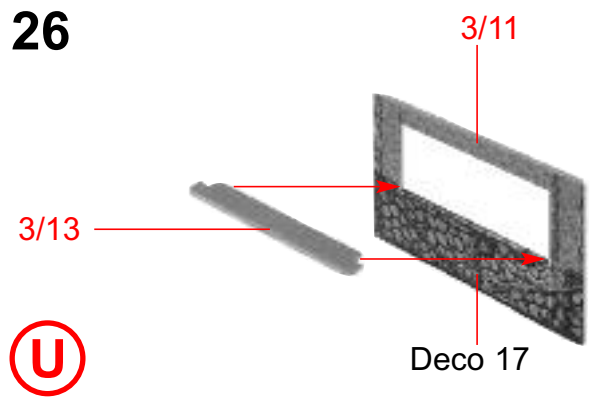

U

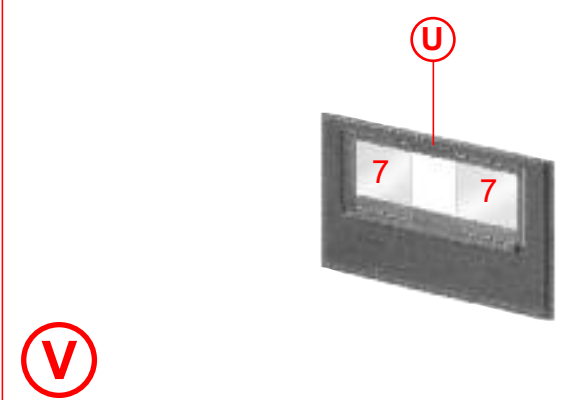

V

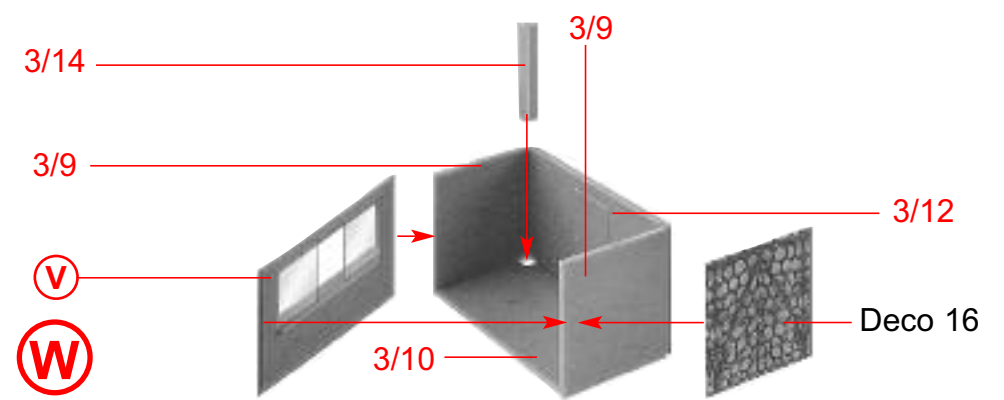

W

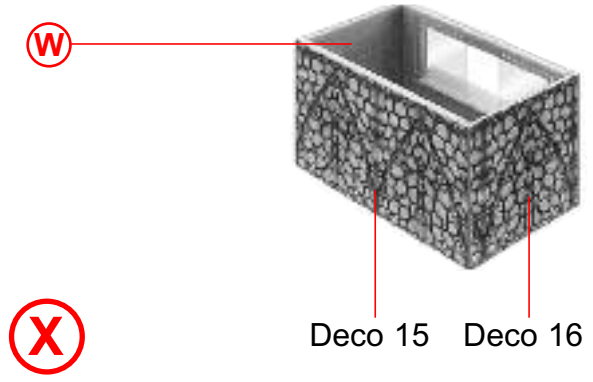

X

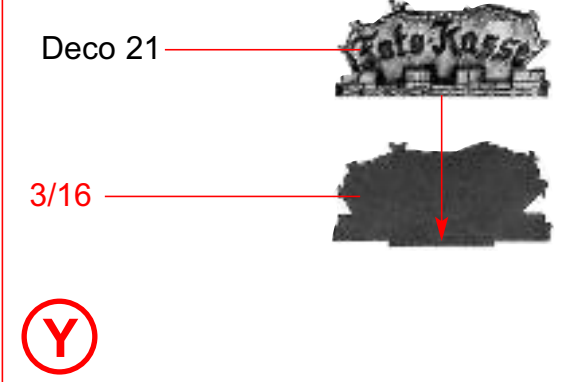

Y

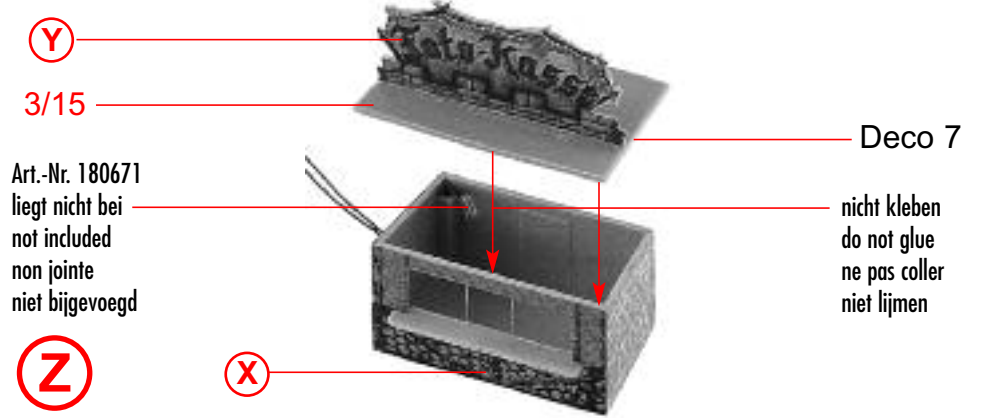

Z

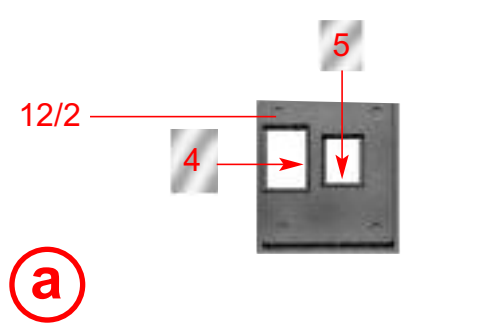

a

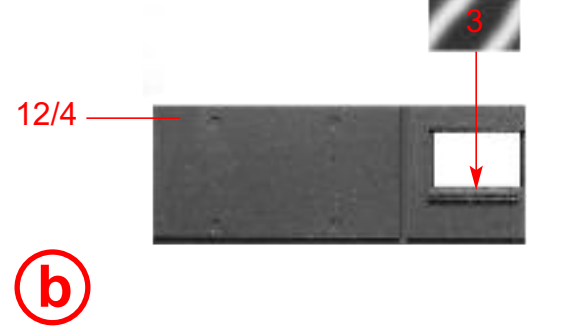

b

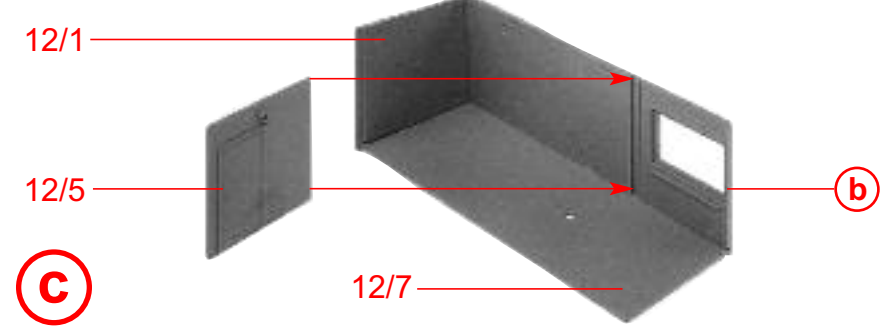

c

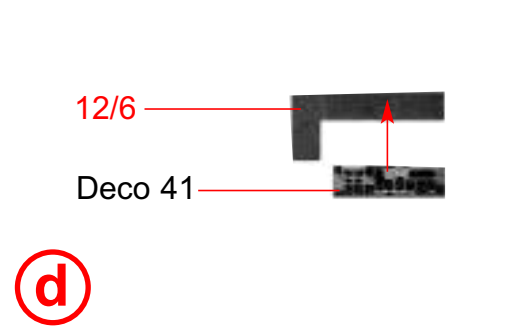

d

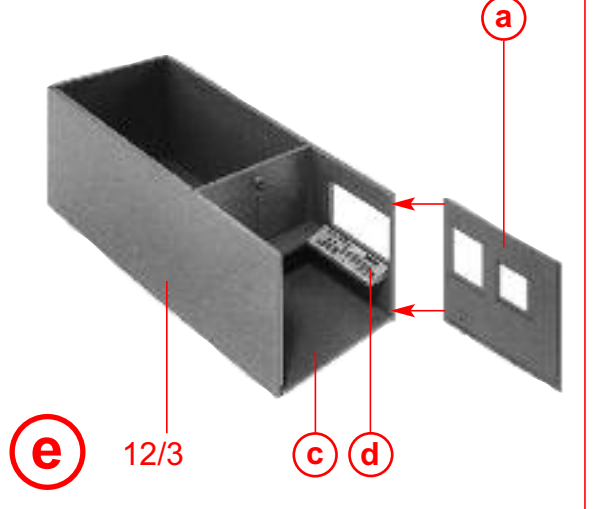

e

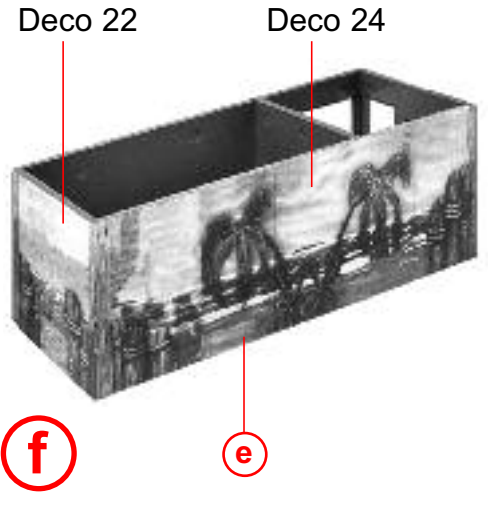

f

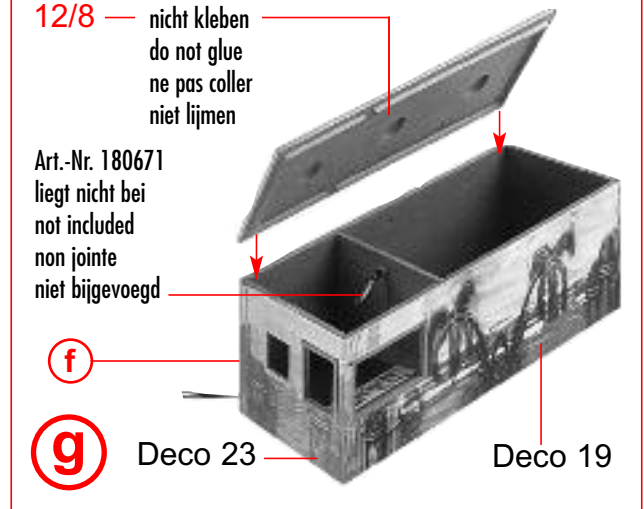

g

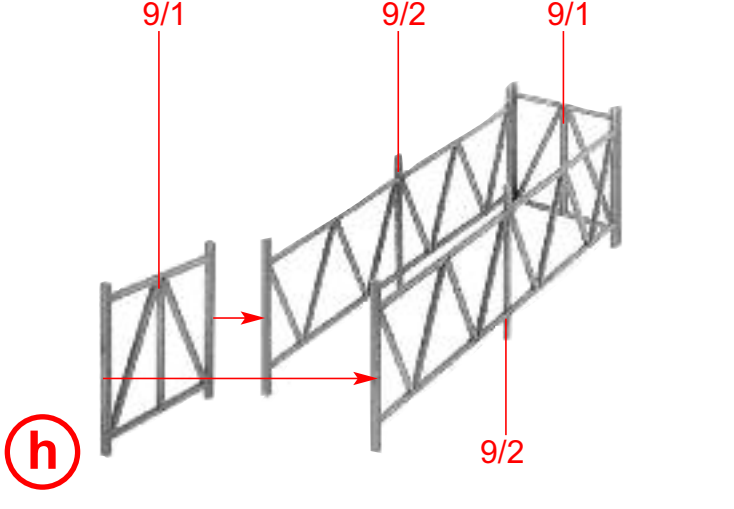

h

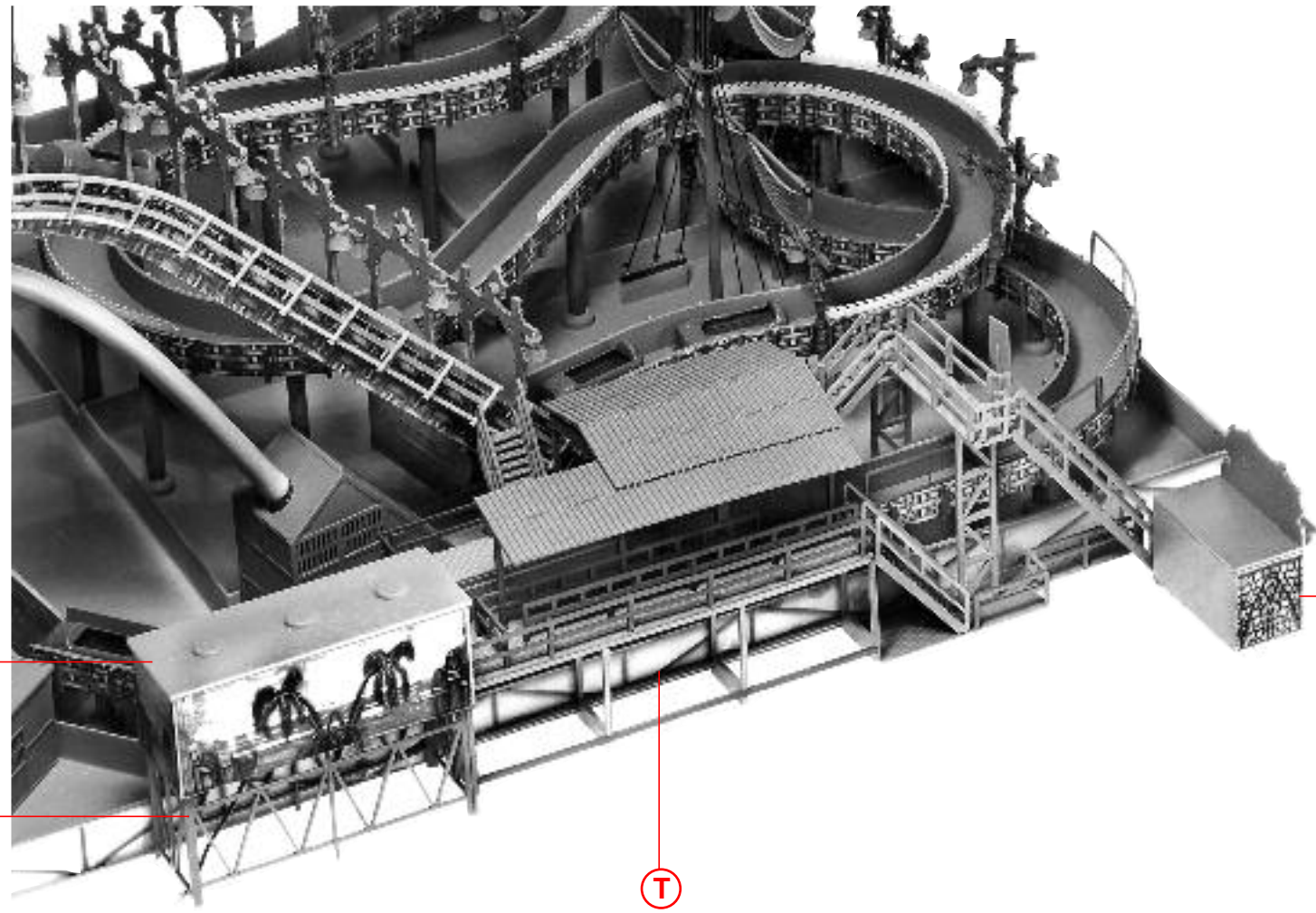

g

h

i

T

Z

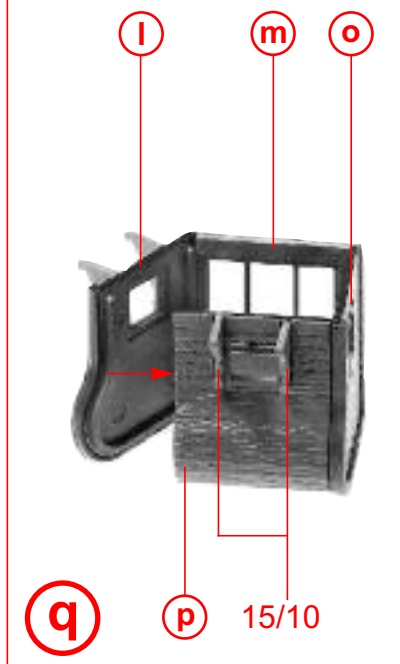
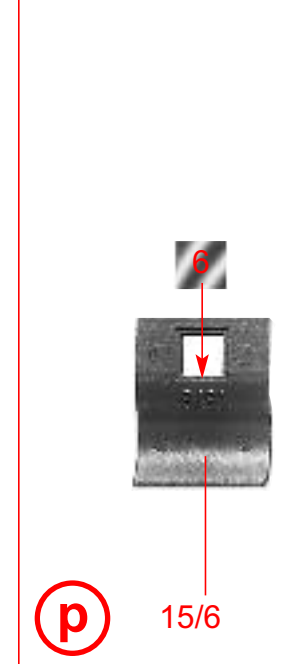
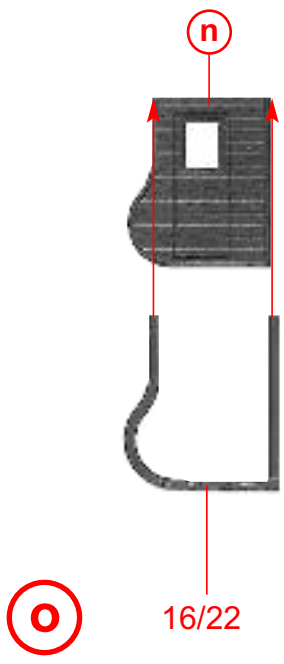
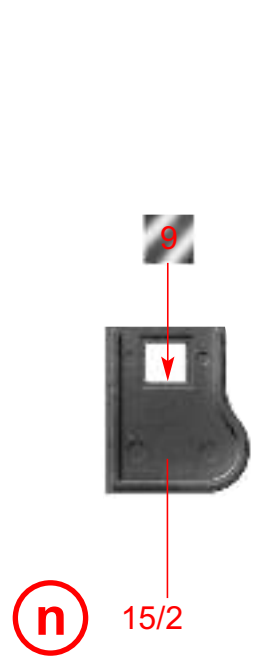
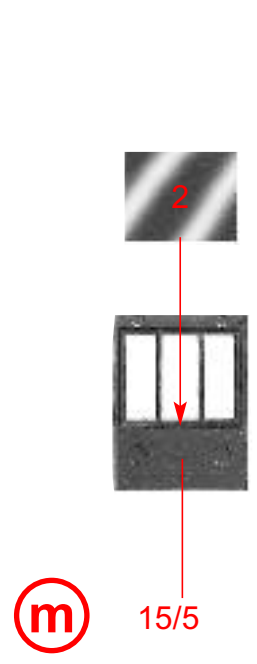
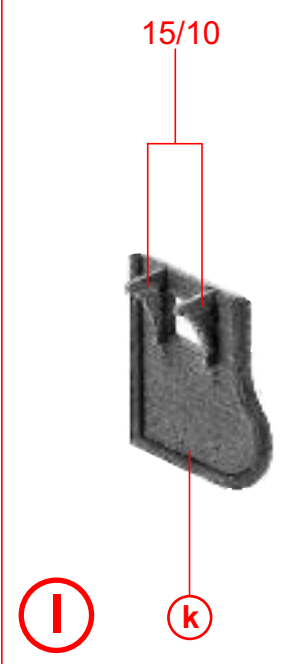
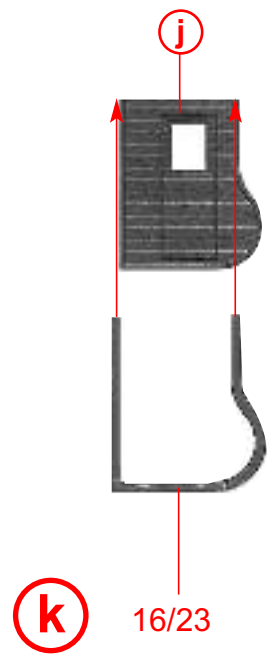
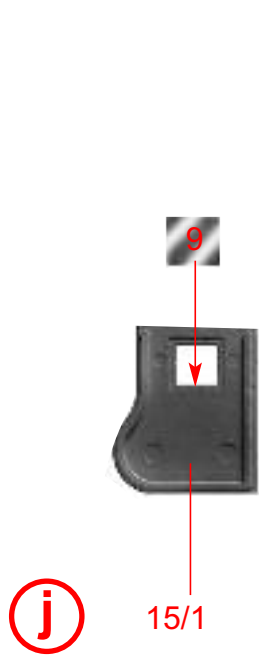

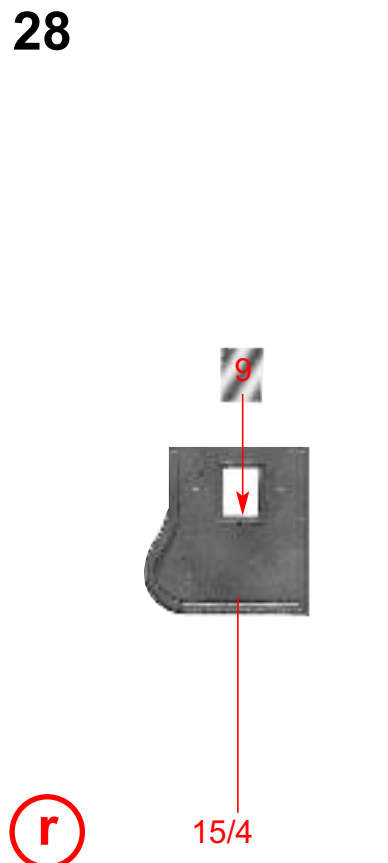

r 15/4

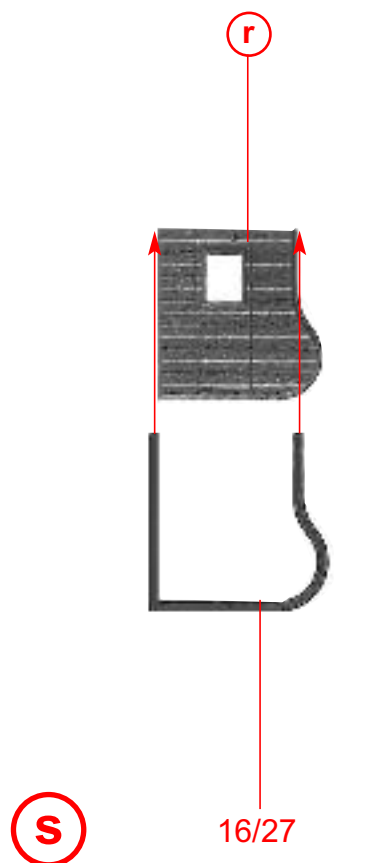

s 16/27

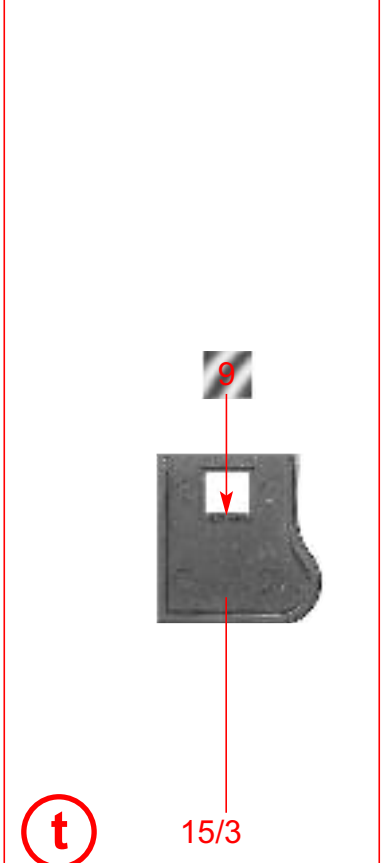

t 15/3

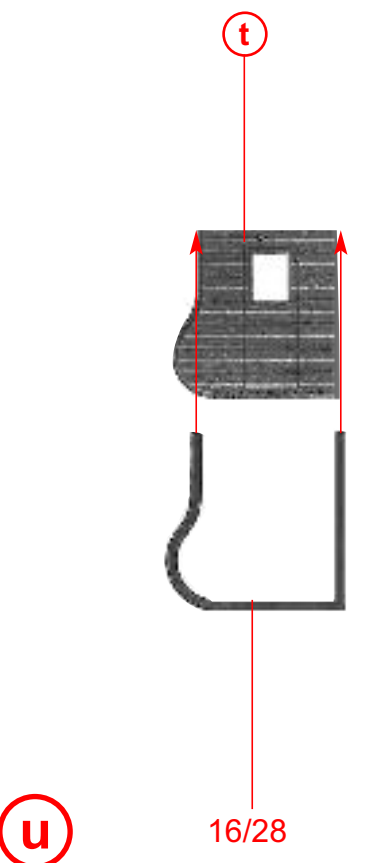

u 16/28

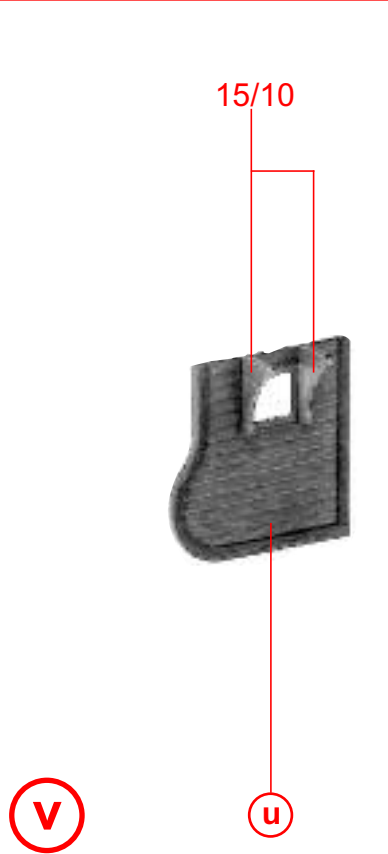

v **u**

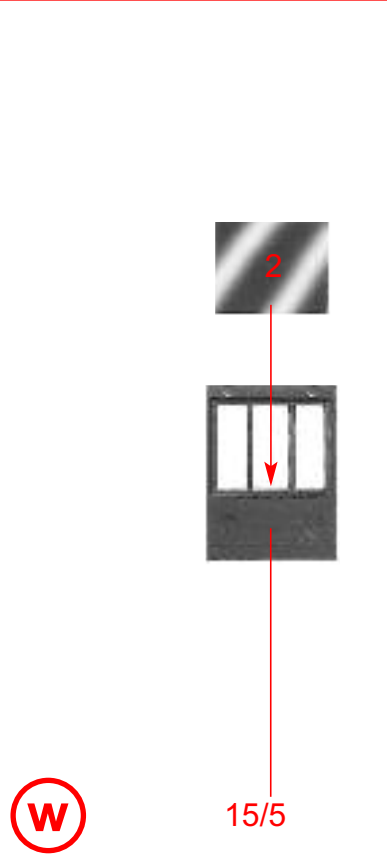

w 15/5

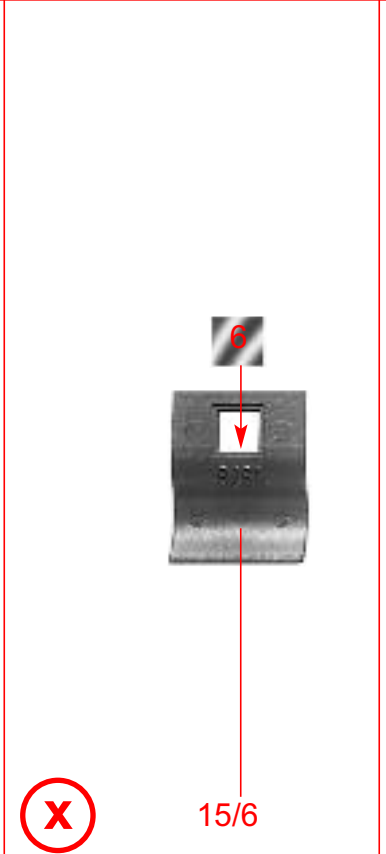

x 15/6

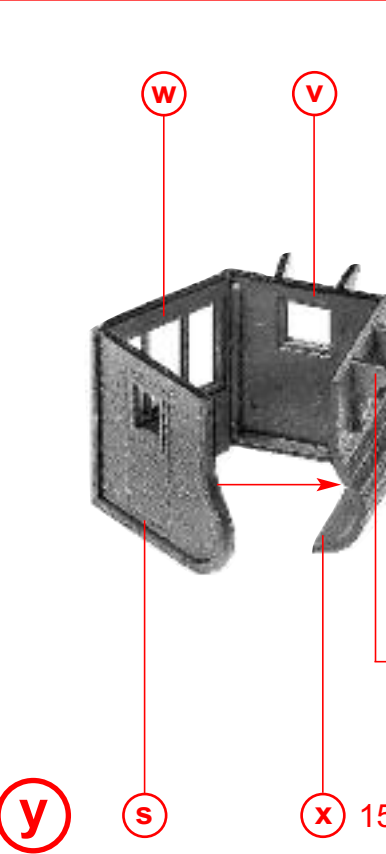

y **s** **x** 15/10

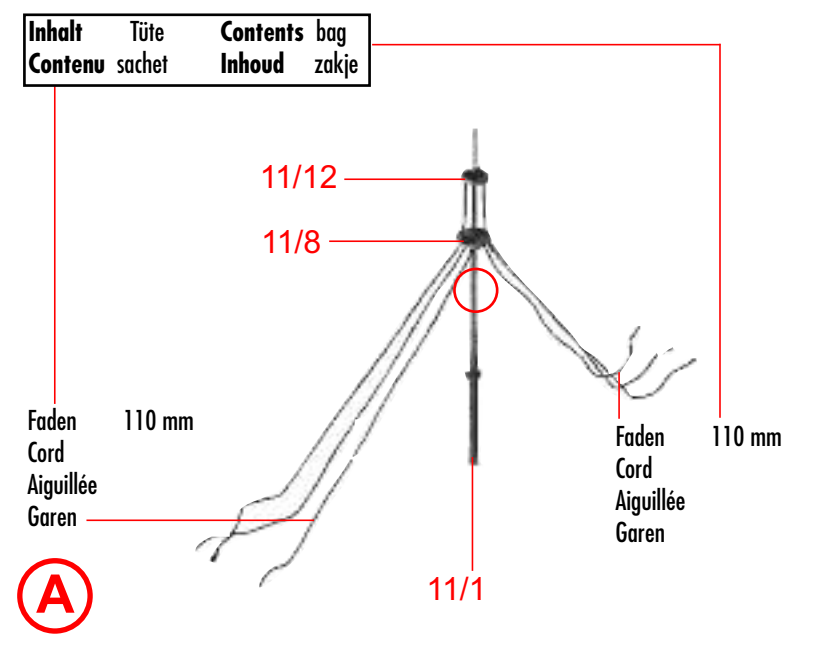

A

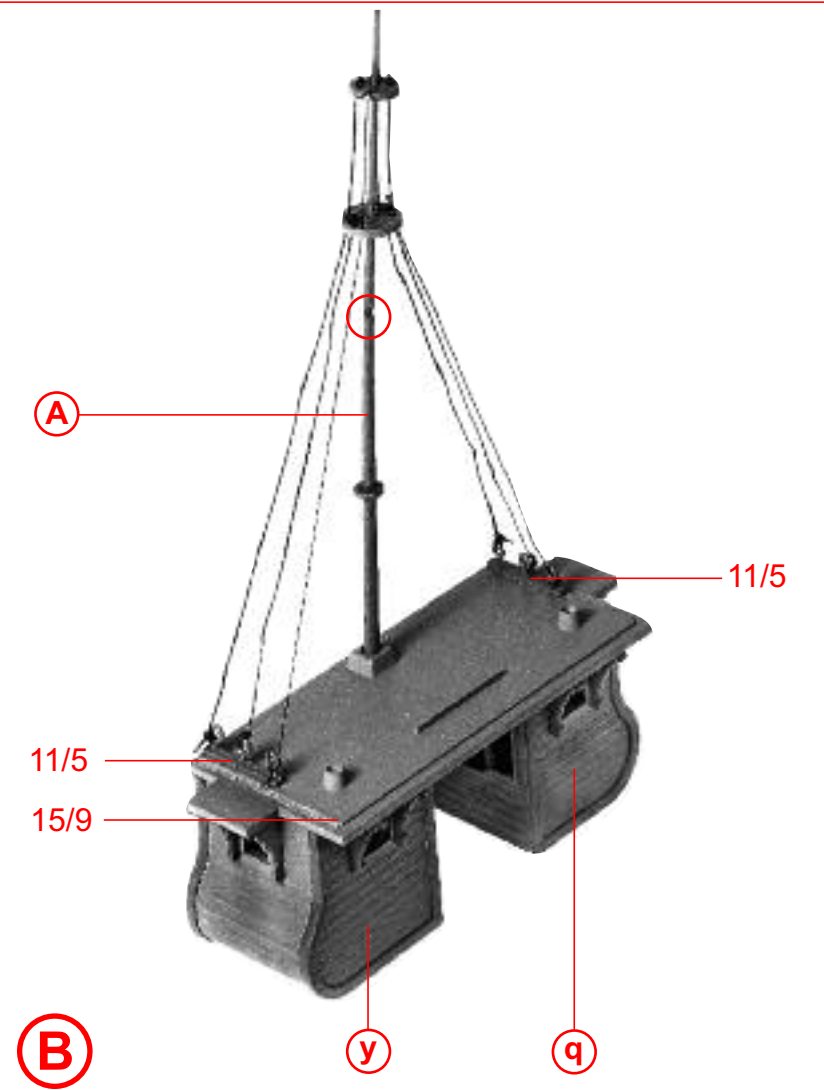

B

Faden Aiguillée
Cord Garen

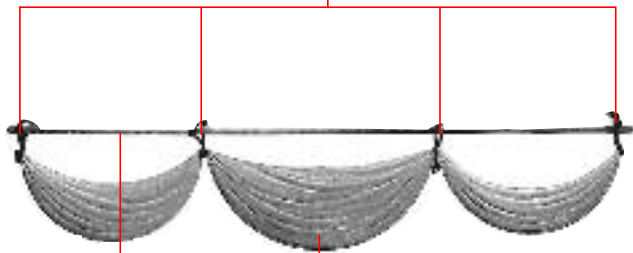

C

11/2

12/11

Art.-Nr. 180671 liegt nicht bei
not included
non jointe
niet bijgevoegd

18/10

nicht kleben
do not glue
ne pas coller
niet lijmen

Inhalt	Tüte	Contents	bag
Contenu	sachet	Inhoud	zakje

D 2 x



nicht kleben
do not glue
ne pas coller
niet lijmen

D

D

C

10/26

B

E

16/29

Sekundenkleber verwenden.
Use instant modelling cement.
Utilisez la colle rapide.
Gebruik seconden - lijm.

Art.-Nr. 180671 liegt nicht bei
not included
non jointe
niet bijgevoegd

E

F

15/8

15/7

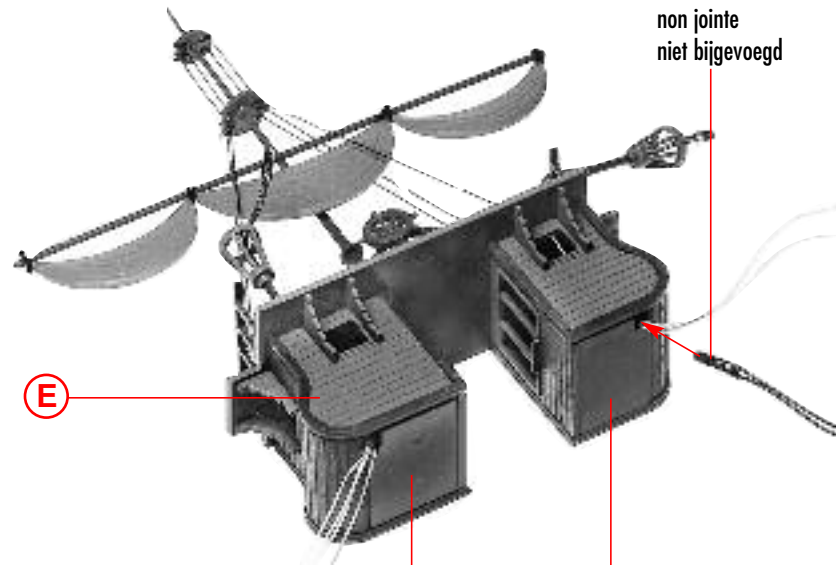

16/21

16/20

G 2 x

Deco 20 29

H

10/24

Inhalt	Tüte	Contents	bag
Contenu	sachet	Inhoud	zakje

Sekundenkleber verwenden.
Use instant modelling cement.
Utilisez la colle rapide.
Gebruik seconden - lijm.

G

F

17/4

I

H

10/25

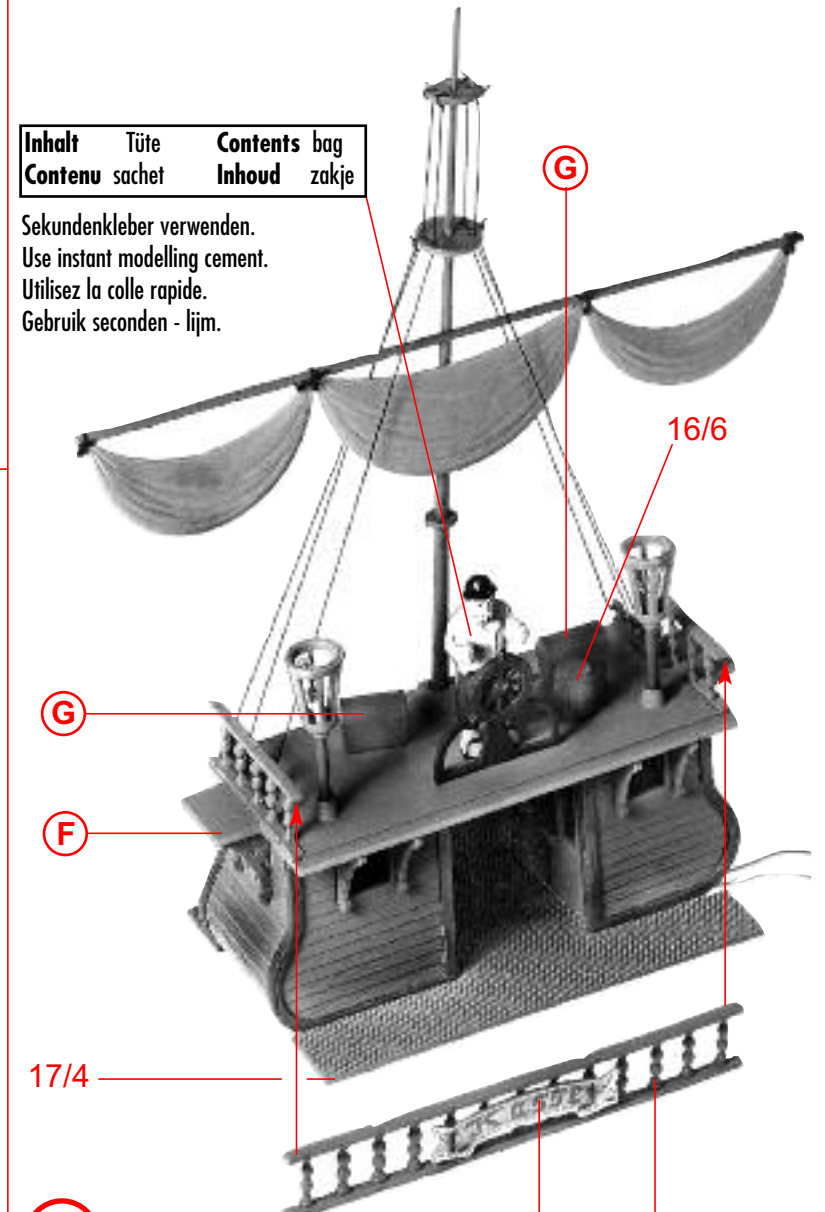

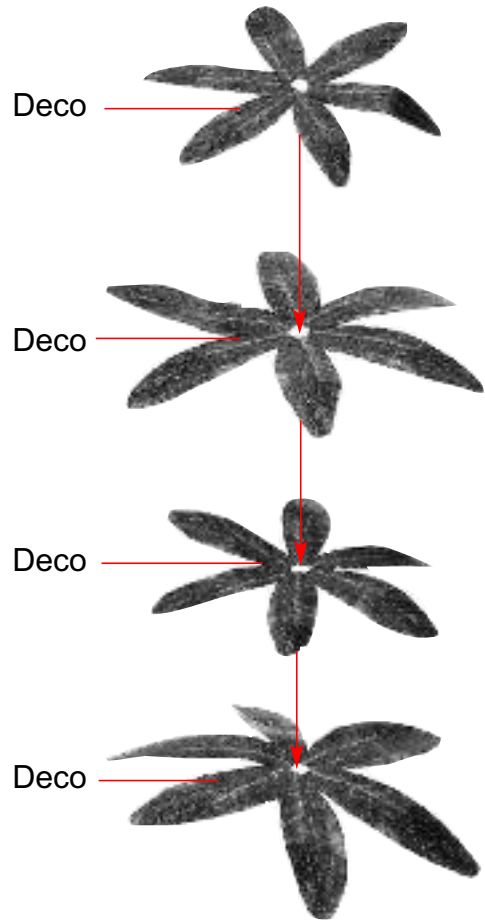

J 2 x

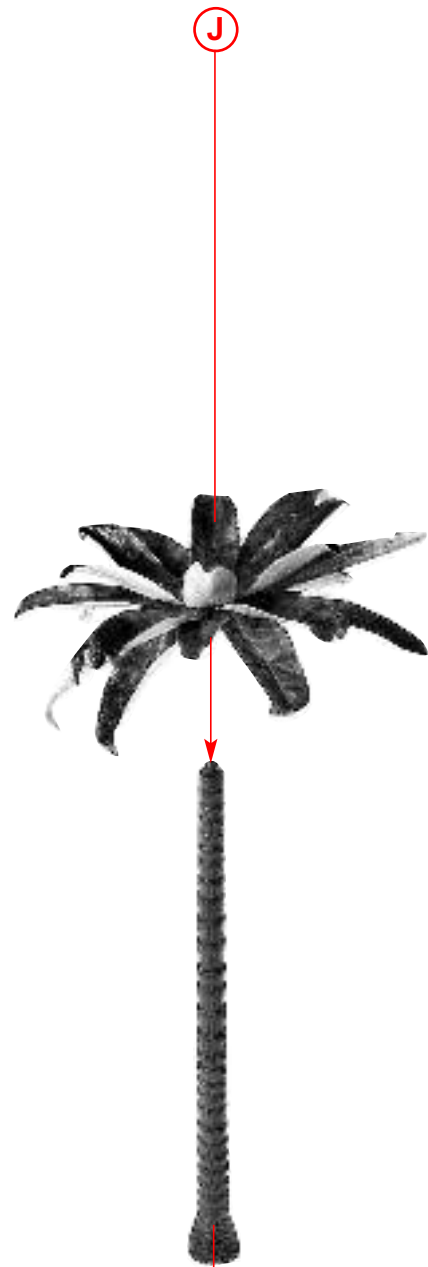

K 2 x 16/3

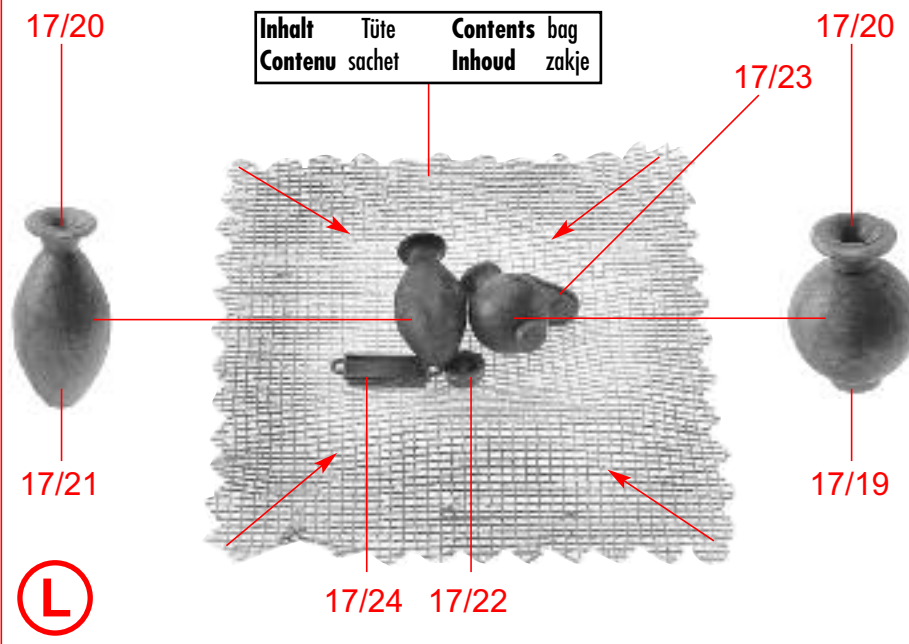

L

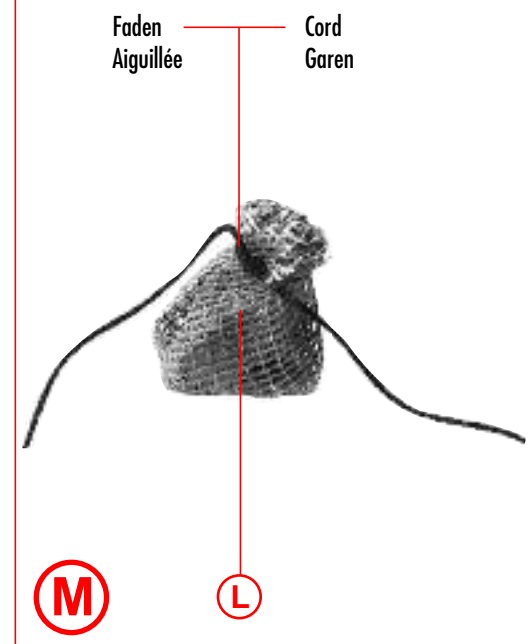

M

L

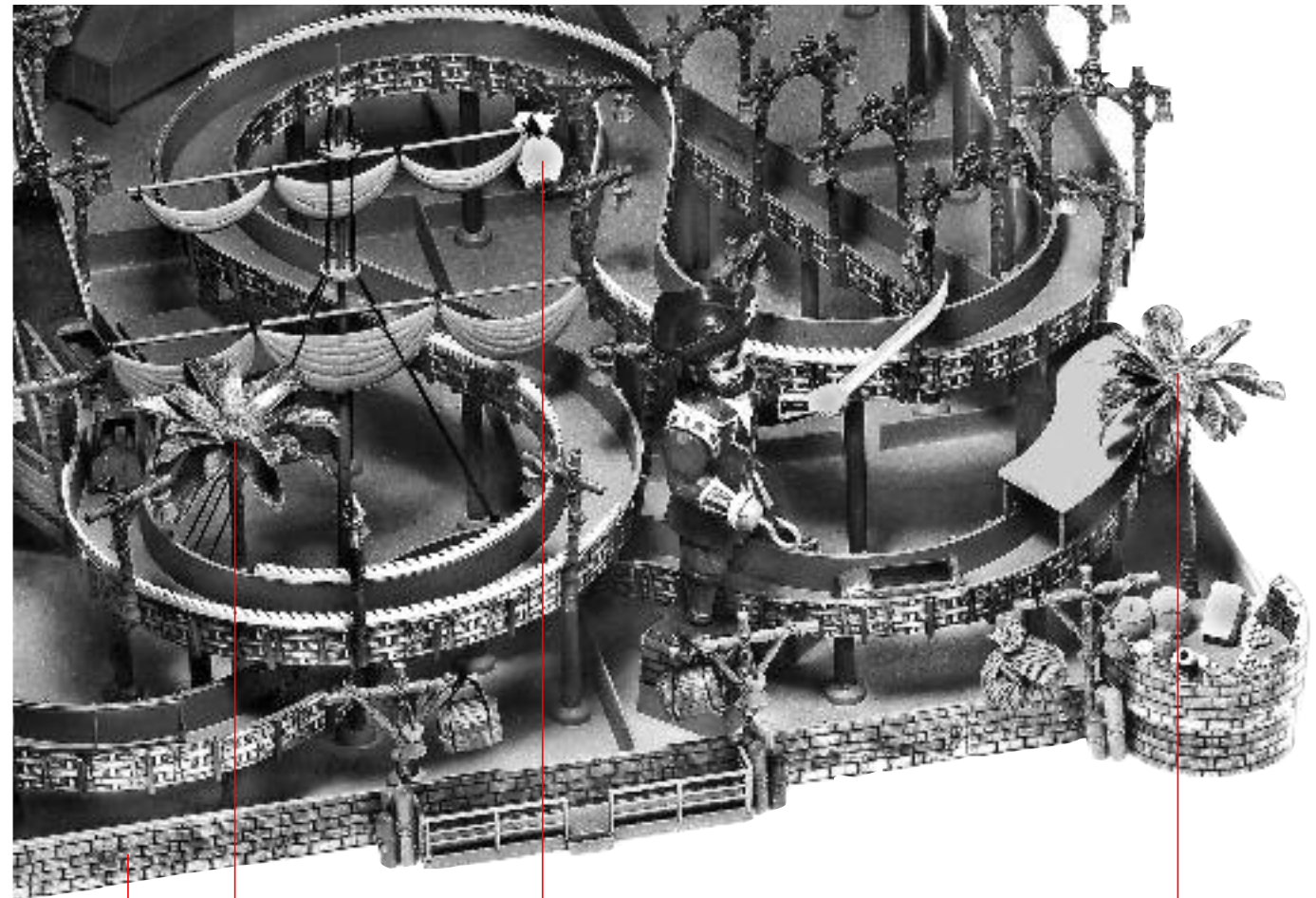

N

i

K

M

K

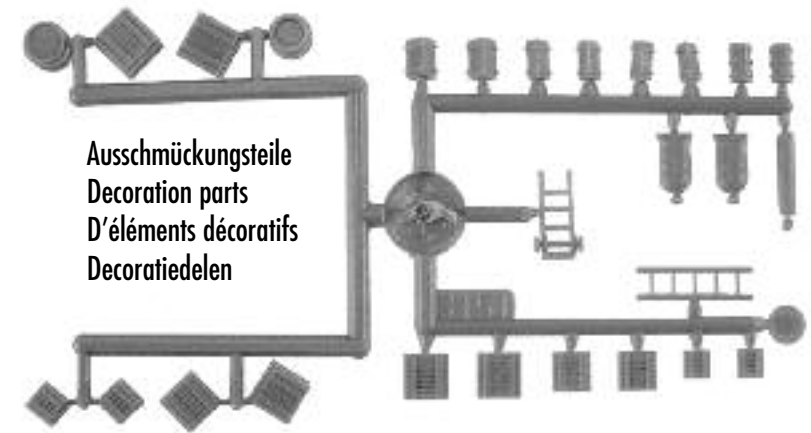
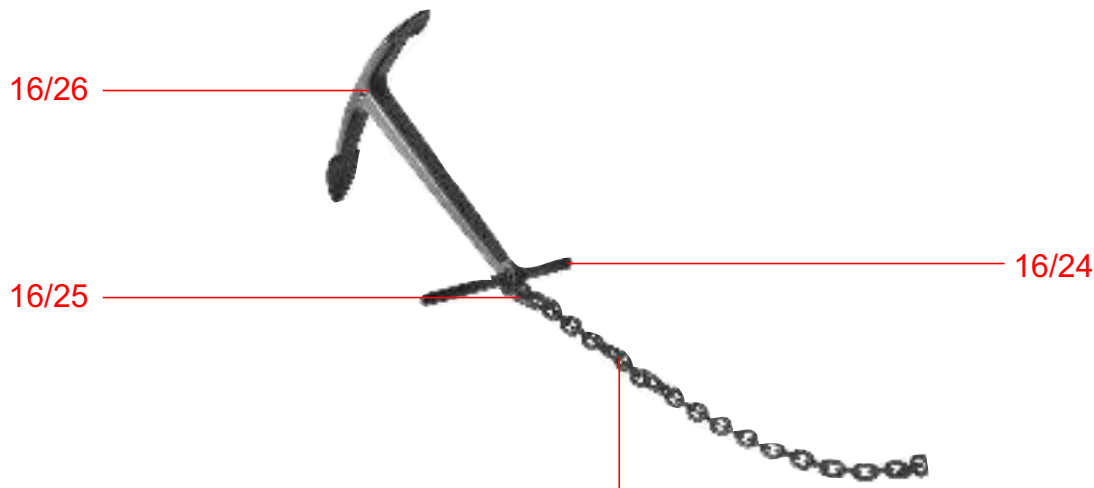
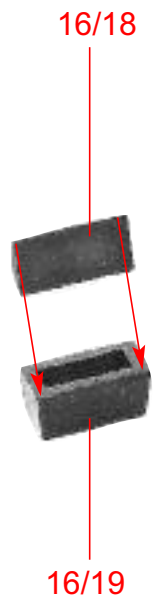

Aussmückungsteile
 Decoration parts
 D'éléments décoratifs
 Decoratiedelen

Ⓞ

Ⓟ

Inhalt	Tüte	Contents	bag
Contenu	sachet	Inhoud	zakje

3151

Aussmückungsteile
 Decoration parts
 D'éléments décoratifs
 Decoratiedelen



Ⓞ

Inhalt	Tüte	Contents	bag
Contenu	sachet	Inhoud	zakje

Sekundenkleber verwenden.
 Use instant modelling cement.
 Utilisez la colle rapide.
 Gebruik seconden - lijm.

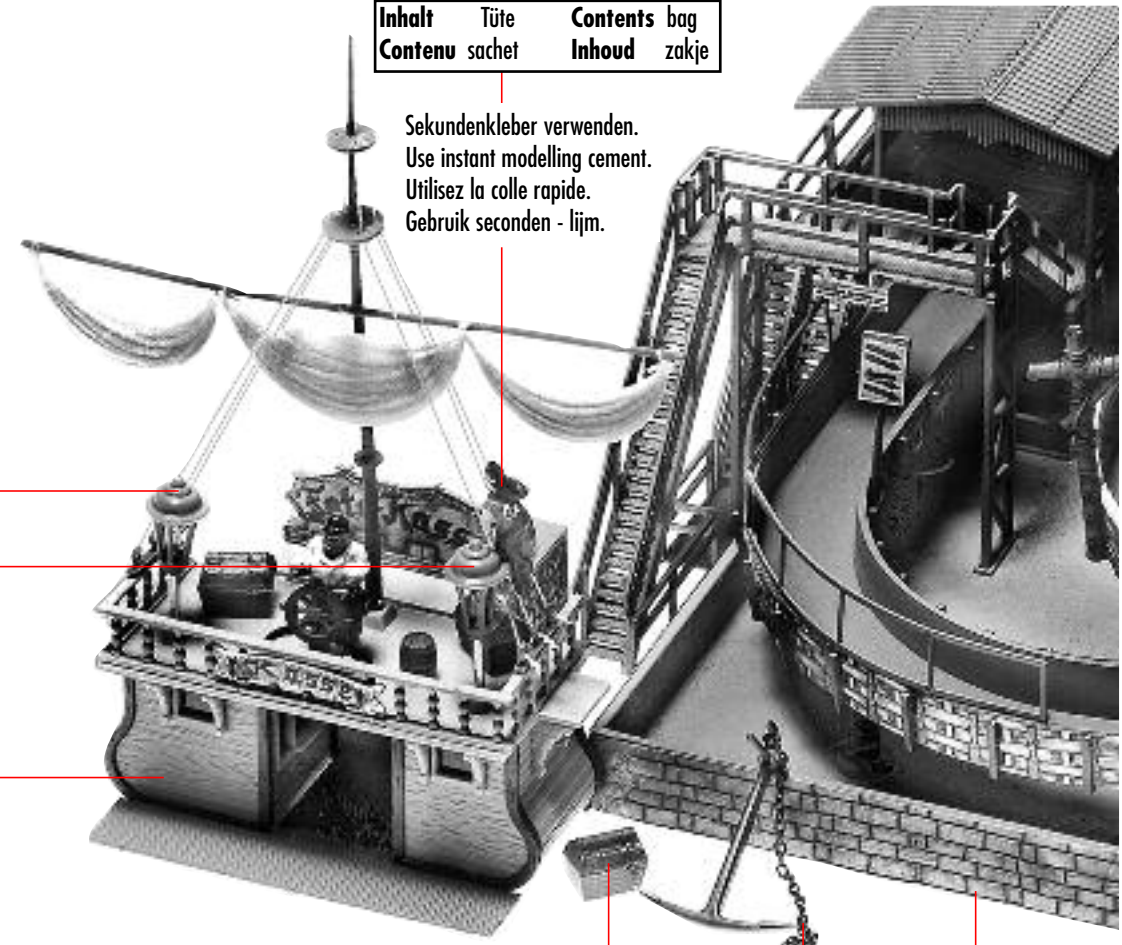

Aussmückungsteile
 Decoration parts
 D'éléments décoratifs
 Decoratiedelen



Ⓞ

18/11

18/11

I

Ⓞ

Ⓞ

Ⓟ

Ⓝ

Pflege- und Service-Hinweise

Bei längerem Nichtbenützen und zur Reinigung der Wildwasserbahn, entleeren Sie bitte das Wasserbecken und beseitigen Sie mittels Lappen und lauwarmem Wasser die Staubablagerungen und evtl. Schmutzrückstände.

ACHTUNG: Keine Reinigungsmittel verwenden, das Wasser schäumt sonst bei neuerlicher Inbetriebnahme !!!

Achten Sie bitte darauf, daß der Wasserspiegel nicht tiefer als die Pumpenansaughöhe sinkt, da ansonsten die Pumpen trockenlaufen und Schaden nehmen können.

Bei Wiederinbetriebnahme nur Wasser auf Rippen-Oberkantenhöhe 8 mm einfüllen.

Sollten Sie anderweitige Fragen haben, unsere Service-Abteilung hilft Ihnen gerne weiter.

Maintenance and service instructions

If the wildwater race track is not used for a longer period of time and for cleaning it, drain the water basin, please, and remove any dust deposits and residual dirt by a rag and lukewarm water.

ATTENTION: Do not use a cleaning agent, else the water will foam on restarting !!!

See to it that the water level does not drop below the pump's suction head, else the pumps may run dry and may suffer damage. For restart, fill in water only up to the rib top edge height of 8 mm.

If you have any more questions, please do not hesitate to contact our service department.

Instructions d'entretien et de maintenance

Lors d'arrêt de longue durée et pour le nettoyage de la trajectoire du torrent, vider le bassin d'eau et enlever avec un chiffon et de l'eau tiède les dépôts de poussière et d'éventuels résidus de saleté.

ATTENTION: ne pas utiliser de produits de nettoyage, sinon l'eau mousse à la remise en service.

Veiller à ce que le niveau d'eau ne descende pas en-dessous de la hauteur d'aspiration de la pompe, sinon les pompes marchent à vide et peuvent être endommagées.

A la remise en service, remettre uniquement de l'eau jusqu'au bord supérieur 8 mm des nervures.

Si vous avez d'autres questions, notre service après-vente est toujours à votre disposition.

Onderhoud- en service-adviezen

Als de wildwater baan langere tijd niet wordt gebruikt en schoongemaakt, moet vóór de eerst volgende ingebruikname alles wat met de »exploitatie« te maken heeft, goed worden schoongemaakt. Laat alles leeglopen en verwijder met een lap en lauwarm water overal alle stof en vuil.

LET OP: gebruik geen schoonmaakmiddel; het water gaat anders schuimen als u opnieuw begint.

Let er vooral op, dat de waterspiegel niet lager komt dan de opzuighoogte van de waterpomp, omdat deze anders droogloopt en beschadigd wordt. Bij opnieuw in gebruik nemen moet water voor vulling tot 8 mm hoog worden ingegoten. Als u nog vragen heeft over dit bouw pakket, kan onze service-afdeling u verder informeren.

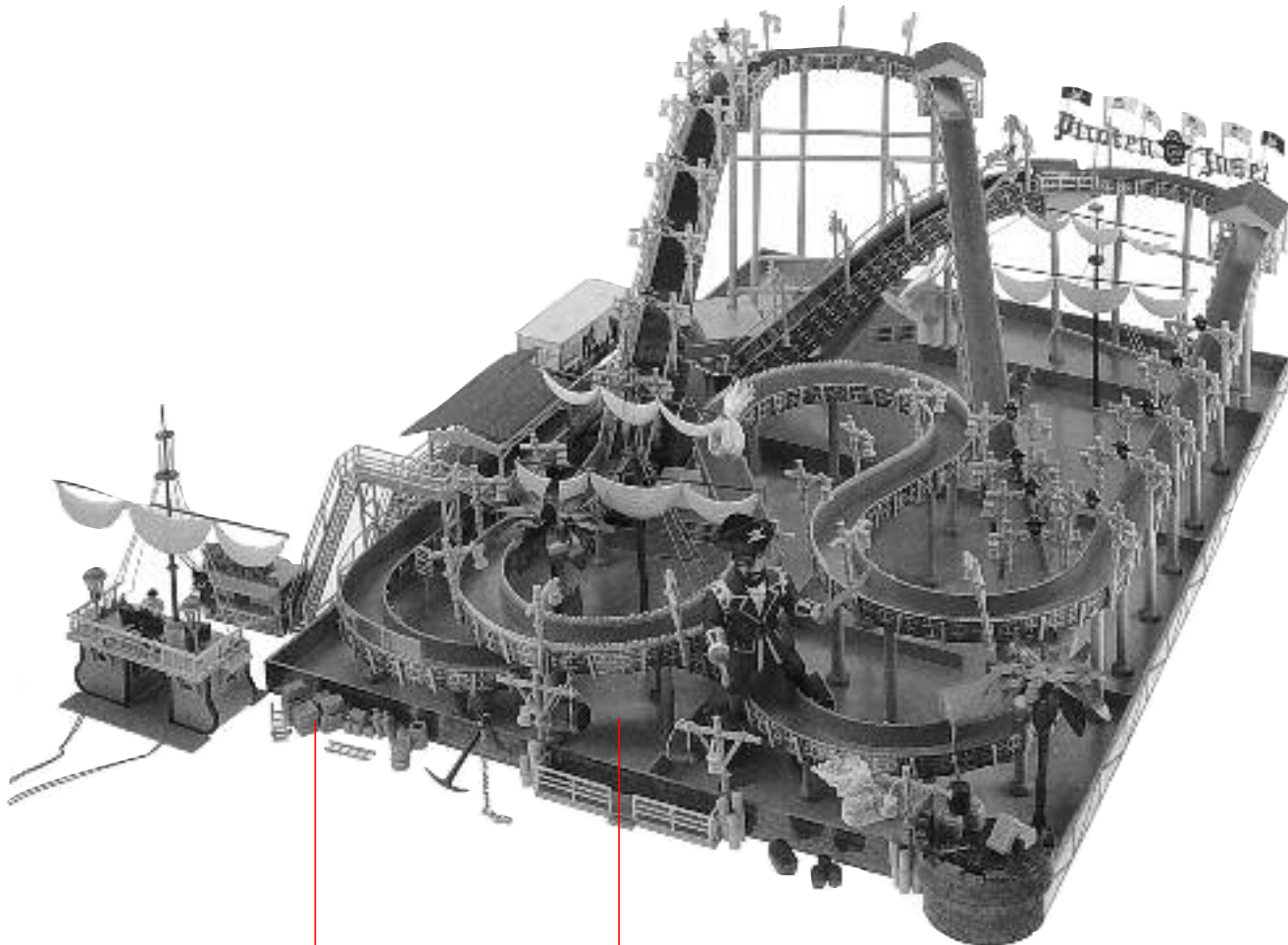

T

R

S